



**Rules of
Department of Revenue
Division 10—Director of Revenue
Chapter 23—Motor Vehicle**

Title	Page
12 CSR 10-23.010 Dealer Plate Allocation (Rescinded July 14, 1982).....	5
12 CSR 10-23.020 Dealer Registration (Rescinded April 29, 1991)	5
12 CSR 10-23.030 Bona Fide Established Place of Business (Rescinded April 29, 1991)	5
12 CSR 10-23.040 Cancellation of Dealer Registration (Rescinded June 11, 1983).....	5
12 CSR 10-23.050 Dealer’s Monthly Reports (Moved to 12 CSR 10-26.190)	5
12 CSR 10-23.070 Regulation of Dealer License Plates.....	5
12 CSR 10-23.100 Personalized License Plates	6
12 CSR 10-23.110 Hearing Held Pursuant to Section 301.257, RSMo (Rescinded April 29, 1991)	10
12 CSR 10-23.120 Business Records of Manufacturers, Dealers and Boat Dealers (Rescinded December 3, 1992).....	10
12 CSR 10-23.130 Legal Name on Title Application	10
12 CSR 10-23.140 Motor Vehicle Title Services	10
12 CSR 10-23.150 Administrative Hearing Held Pursuant to Section 301.119, RSMo	16
12 CSR 10-23.160 Good Moral Character of Motor Vehicle Dealers, Manufacturers, Boat Dealers, Salvage Dealers and Title Service Agents	16
12 CSR 10-23.170 Registration of Corporation Motor Vehicles/Emission System Inspection Areas (Rescinded November 30, 2007).....	17
12 CSR 10-23.180 Replacement Vehicle Identification Plates	17
12 CSR 10-23.185 Obscene License Plates	17
12 CSR 10-23.190 Temporary Permits Sold by a Registered Missouri Motor Vehicle Dealer (Moved to 12 CSR 10-26.180).....	19



12 CSR 10-23.200	Nonnegotiable Certificate of Title to a Motor Vehicle or Trailer (Rescinded September 9, 1993)	19
12 CSR 10-23.210	Congressional Medal of Honor License Plates.....	19
12 CSR 10-23.220	Motor Vehicle Fee and Tax Refund Requests (Rescinded November 30, 2007)	19
12 CSR 10-23.230	Legal Sale of Motor Vehicle or Trailer.....	19
12 CSR 10-23.240	Recording of Mileage on an Application for Certificate of Title (Rescinded July 8, 1991)	19
12 CSR 10-23.250	Registration and Classification of Commercial Motor Vehicles.....	19
12 CSR 10-23.255	Issuance of New and Replacement Vehicle Identification Numbers	20
12 CSR 10-23.260	Inspection of Foreign Motor Vehicles Prior to Titling.....	20
12 CSR 10-23.265	Statements of Non-Interest	24
12 CSR 10-23.270	Watercraft and Outboard Motor Identification Numbers	24
12 CSR 10-23.275	Recognition of Nonresident Disabled Person Windshield Placards	25
12 CSR 10-23.280	Replacement of Multiyear License Plates.....	25
12 CSR 10-23.285	Titling of Motor Vehicles Sold Without Safety Inspections (Rescinded November 30, 2007)	25
12 CSR 10-23.290	Use of License Plates After Name Change.....	25
12 CSR 10-23.295	Witnessing Proof of Federal Heavy Vehicle Use Tax Payment or Exemption	26
12 CSR 10-23.300	Use of Local Commercial Motor Vehicle License Plates for Farm or for Farming Transportation Operations	27
12 CSR 10-23.305	No-Fee Transactions	27
12 CSR 10-23.310	Issuance of Special Fuel Decals	27
12 CSR 10-23.315	Motorized Bicycles.....	28
12 CSR 10-23.320	Assessment of Motor Vehicle and Trailer License Plate Transfer Fee	28
12 CSR 10-23.325	Transfer of Passenger Vehicle License Plates From One Horsepower Category to Another—Waiver of Additional Registration Fees and Lack of Refund Provision	28
12 CSR 10-23.330	Registration of Motorcycles or Motortricycles	28

12 CSR 10-23.335	Issuance of Title to a Surviving Spouse or Unmarried Minor Children of a Decedent.....	29
12 CSR 10-23.340	Imposition and Waiver of Motor Vehicle and Trailer Titling and Registration Penalties.....	29
12 CSR 10-23.345	Definition of Major Component Parts of a Motor Vehicle.....	30
12 CSR 10-23.350	Honorary Consular License Plates.....	32
12 CSR 10-23.355	Junking Certificates for Motor Vehicles.....	33
12 CSR 10-23.365	Issuance of Nonresident Salvage-Buyer’s Identification Card (Rescinded February 29, 2008).....	33
12 CSR 10-23.370	Issuance of Certificates of Title to Recreational Vehicles Manufactured by Two Separate Manufacturers.....	33
12 CSR 10-23.375	Fire Department License Plates (Rescinded March 30, 2005).....	34
12 CSR 10-23.380	Motor Vehicle Shows or Tent Sales (Rescinded April 29, 1991).....	34
12 CSR 10-23.385	Verification of the Vehicle Identification Number and Odometer Reading of Motor Vehicles Previously Titled in Another State.....	34
12 CSR 10-23.390	License Plates for Disabled Veterans (Rescinded May 30, 2006).....	34
12 CSR 10-23.395	Regulation of Boat Dealer’s Certificate of Number and Plates.....	34
12 CSR 10-23.400	Transfer of License Plates.....	35
12 CSR 10-23.405	Emblem Use Authorization Statement and Format for Collegiate License Plates.....	35
12 CSR 10-23.410	Certificate of Registration to Documented Vessels (Rescinded February 25, 1996).....	36
12 CSR 10-23.415	Sample License Plates (Rescinded November 30, 2007).....	36
12 CSR 10-23.420	Secure Power of Attorney Requirements.....	36
12 CSR 10-23.422	Issuance of Purple Heart License Plates (Rescinded February 28, 2007).....	37
12 CSR 10-23.424	Leasing Company Registration.....	37
12 CSR 10-23.426	Special Identification Numbers.....	37
12 CSR 10-23.428	All-Terrain Vehicles Modified for Highway Use (Rescinded December 30, 2005).....	41
12 CSR 10-23.430	Registration of a Motor Vehicle or Trailer When the Out-Of-State Lienholder Refuses to Release the Title.....	41



12 CSR 10-23.432	Registration of a Motor Vehicle or Trailer Subject to a Lease With a Right to Purchase Clause	41
12 CSR 10-23.434	Use of a Reassignment of Ownership by Registered Dealer Form	41
12 CSR 10-23.436	Application For Title (Rescinded December 30, 2003)	44
12 CSR 10-23.440	Replacement License Tabs (Rescinded May 30, 2006)	44
12 CSR 10-23.442	Outboard Motor	44
12 CSR 10-23.444	Historic Vehicle License (Rescinded December 30, 2003)	44
12 CSR 10-23.446	Notice of Lien	44
12 CSR 10-23.450	Guidelines for Use of Handicapped Parking Cones	44
12 CSR 10-23.452	Internet Renewal of License Plates	45
12 CSR 10-23.454	Electric Personal Assistive Mobility Device (EPAMD)	45
12 CSR 10-23.456	Marine Application for Title	45
12 CSR 10-23.458	Documents Accepted as a Release of Lien	45
12 CSR 10-23.460	Issuance of Biennial Disabled Person Placard (Rescinded November 30, 2007)	46
12 CSR 10-23.465	Issuance of Biennial Salvage Business Licenses	46
12 CSR 10-23.470	Notice of Sale	46



**Title 12—DEPARTMENT OF
REVENUE**

**Division 10—Director of Revenue
Chapter 23—Motor Vehicle**

12 CSR 10-23.010 Dealer Plate Allocation
(Rescinded July 14, 1982)

AUTHORITY: section 301.250.4, RSMo 1978. This version of rule filed Oct. 21, 1974, effective Oct. 31, 1974. Rescinded: Filed March 12, 1982, effective July 14, 1982.

12 CSR 10-23.020 Dealer Registration
(Rescinded April 29, 1991)

AUTHORITY: section 301.251, RSMo 1986. Original rule filed April 14, 1980, effective Sept. 12, 1980. Amended: Filed March 26, 1982, effective July 12, 1982. Emergency amendment filed Aug. 14, 1984, effective Aug. 24, 1984, expired Dec. 22, 1984. Amended: Filed Aug. 14, 1984, effective Dec. 13, 1984. Amended: Filed May 27, 1986, effective Aug. 25, 1986. Rescinded: Filed Nov. 15, 1990, effective April 29, 1991.

**12 CSR 10-23.030 Bona Fide Established
Place of Business**
(Rescinded April 29, 1991)

AUTHORITY: section 301.251, RSMo 1986. Original rule filed April 14, 1980, effective Sept. 12, 1980. Amended: Filed March 26, 1982, effective July 12, 1982. Amended: Filed April 29, 1983, effective Sept. 11, 1983. Amended: Filed Dec. 5, 1983, effective March 11, 1984. Amended: Filed Feb. 3, 1984, effective May 11, 1984. Emergency amendment filed Aug. 14, 1984, effective Aug. 24, 1984, expired Dec. 22, 1984. Amended: Filed Aug. 14, 1984, effective Dec. 13, 1984. Amended: Filed May 23, 1985, effective Aug. 26, 1985. Amended: Filed May 27, 1986, effective Aug. 25, 1986. Rescinded: Filed Nov. 15, 1990, effective April 29, 1991.

**12 CSR 10-23.040 Cancellation of Dealer
Registration**
(Rescinded June 11, 1983)

AUTHORITY: section 301.257, RSMo Supp. 1982. Original rule filed April 14, 1980, effective Sept. 12, 1980. Amended: Filed March 26, 1982, effective July 12, 1982. Rescinded: Filed March 4, 1983, effective June 11, 1983.

**12 CSR 10-23.050 Dealers' Monthly
Reports**

(Moved to 12 CSR 10-26.190)

**12 CSR 10-23.070 Regulation of Dealer
License Plates**

PURPOSE: The director of the Department of Revenue is charged with the responsibility of regulating the license plates issued to dealers. This rule establishes safeguards to prevent unauthorized use of dealer plates.

(1) Whenever a dealer is no longer entitled to registration pursuant to section 301.251, RSMo through voluntary cessation of business, abandonment of a bona fide established place of business, failure to make four (4) sales per year, suspension or revocation of its registration, sale of the business, declaration of bankruptcy or for any other reason, the dealer license plates issued to that dealer immediately shall be surrendered to the director regardless of the unexpired time remaining in the registration period applicable to that license plate.

(2) Dealer license plates are issued primarily for the purpose of allowing a potential buyer to test drive a motor vehicle owned and held for resale by a dealer. A secondary purpose is to allow the transportation of vehicles owned by a dealer or manufacturer and held for the purpose of resale. Therefore, dealer plates may be displayed only on a motor vehicle or trailer that is—

- (A) Owned by the manufacturer/dealer; and
- (B) Held for resale.

(3) Vehicles on which the plates are displayed then may be operated by—

- (A) A customer who is test driving the motor vehicle;
- (B) An owner, officer or employee of the manufacturer/dealer;
- (C) A buyer as provided in section 301.140.3, RSMo; or
- (D) A customer who is test driving a truck or a trailer under loaded conditions provided a written demonstration agreement signed by the prospective customer and the dealer is present in the vehicle. The motor vehicle or trailer may be test driven for no more than twenty-four (24) hours if the vehicle is being operated in Missouri or for one (1) round trip only if being test driven outside Missouri.

The written demonstration agreement must be on the dealership's stationery and include the following items:

1. A statement that the vehicle is being used for demonstration purposes only;
2. A description of the vehicle; that is, year, make and vehicle identification number;
3. The name of the person or company demonstrating the vehicle;
4. The dealer number;
5. A statement of the type of property being transported;
6. The date and time the demonstration began; and
7. If the vehicle is being demonstrated on a round trip outside Missouri, the estimated date the vehicle will be returned to the dealership.

(4) Section 301.253, RSMo provides that dealer plates may be displayed on any motor vehicle used by an employee or officer and owned by the manufacturer, distributor or dealer, but shall not be displayed on any motor vehicle or trailer hired or loaned to others or upon any regularly used service or wrecker vehicle. Therefore, dealer license plates may not be displayed on the following:

- (A) Motor vehicles or trailers that are rented or leased;
- (B) Motor vehicles or trailers that are loaned to someone other than an owner, officer or employee of the dealership (for example, a dealer may not loan a motor vehicle displaying a dealer license plate to his/her customer while the customer's vehicle is being serviced or repaired);
- (C) Motor vehicles or trailers that are used for hauling or towing;
- (D) Motor vehicles or trailers used by anyone who is not an officer or employee of the manufacturer/dealer, this includes relatives of employees and officers;
- (E) Motor vehicles or trailers that are not for resale; and
- (F) Any boat or vessel.

(5) Dealer plates displayed on all motor vehicles, other than motorcycles and motortricycles, must be twelve inches by six inches (12" × 6") in size.

AUTHORITY: sections 301.140, 301.251 and 301.253, RSMo 1986. Original rule filed April 14, 1980, effective Sept. 12, 1980. Amended: Filed March 26, 1982, effective July 12, 1982. Amended: Filed Sept. 16, 1985, effective Jan. 26, 1986.*

**Original authority 301.140, RSMo 1939, amended 1947, 1951, 1978, 1979, 1986, 1987; 301.251, RSMo 1981,*



amended 1984, 1985, 1986; 301.253, RSMo 1981, amended 1985, 1986.

12 CSR 10-23.100 Personalized License Plates

PURPOSE: This rule establishes categories of specialized personalized license plates as well as the procedure for application for and issuance of the personalized license plates.

- (1) For the purpose of this rule, "special license plates" shall include personalized, collegiate, helping schools and other special organizational license plates.
- (2) Special license plates are Missouri license plates containing letters or numbers in the format requested by the applicant. The combination of letters and/or numbers may include one apostrophe (') or one dash (—).
- (3) All special personalized license plates are available in the following plate categories:
 - (A) Passenger;
 - (B) Recreational Vehicle;
 - (C) Local 6;
 - (D) Local 12;
 - (E) Beyond Local 6;
 - (F) Beyond Local 12;
 - (G) Motorcycle/Motortricycle;
 - (H) Local and Beyond Local 18—Professional Sports Team license plates only;
 - (I) Shuttle Bus—regular personalized plates only;
 - (J) Van Pool—regular personalized plates only; and
 - (K) Historic—regular personalized plates only.
- (4) No special license plate will be issued which will conflict with any license number used or to be used in the regular license plate numbering system.
- (5) No two (2) owners shall be issued identical plates; and no plates shall be issued containing or suggesting any profane or obscene word or phrase.
- (6) No refunds will be made on the unused portion of any license plates surrendered for special license plates.
- (7) Special license plates are not assigned to a particular vehicle until the plates are actually issued to the owner of that vehicle by the Department of Revenue.
- (8) Special license plates shall not be transferred from one (1) owner to another, except that the holder of a special plate may follow the procedures established by the director in order to display his/her special plate on a vehicle leased by the holder after approval by the director; and they shall not be transferred from one (1) vehicle category to another. This includes any request for transfer by gift, trust, will or judicial proceeding.
- (9) The director of revenue shall reserve the right to approve or disapprove any request for special license plates or the transfer of license plates from one (1) vehicle to another in the same category.
- (10) The month of expiration on all special license plates for motorcycles and motortricycles will be April of each year. Special license plates issued to the United States Congress, Missouri State Senate, Missouri House of Representatives and the following statewide elected officials: governor, lieutenant governor, secretary of state, state auditor, state treasurer and attorney general, which are issued in accordance with section 301.144, RSMo will expire in January of each year. The month of expiration on all other special license plates shall be staggered.
- (11) Any person wanting to obtain special license plates must make original application for the plates on a form approved by the director of revenue and shall pay a fee of fifteen dollars (\$15) in addition to the regular registration fees. If at the time of registration the applicant applies for a biennial registration, s/he must submit a second special/personalized license plate fee. Application forms will be available to the public at all branch offices, fee agent offices and the Central Office of the department.
- (12) Each initial application for special license plates shall be on a form prescribed by the director and submitted to the Department of Revenue, P.O. Box 100, Jefferson City, MO 65105-0100. Each application shall be accompanied by a special license plate fee of fifteen dollars (\$15), and a current emblem-use authorization statement in the case of collegiate license plates.
- (13) If the applicant applies for a biennial registration at the time s/he picks up his/her special license plates, the applicant must submit a second emblem-use authorization statement indicating the minimum donation or the original emblem-use authorization statement indicating twice the annual minimum donation.
- (14) An applicant may receive his/her special license plates by surrendering his/her regular registration plates and paying any additional fees due on a prorated basis or by not surrendering his/her plates and paying the full registration fee.
- (15) Once an owner obtains special license plates s/he shall have first priority on those plates for each of the following years that s/he makes timely and appropriate reapplication (renewal) for those plates and pays the annual special plate fee of fifteen dollars (\$15) or thirty dollars (\$30) for a biennial registration and any personalized plate fee required by law, in addition to the regular registration fees. Applicants who renew collegiate license plates, helping schools and special organizational license plates must also submit a new emblem-use authorization statement. At the time of renewal, if the applicant elects a biennial registration, s/he must present an emblem-use statement that reflects at least twice the amount of the annual donation.
- (16) Special license plates for which the Department of Revenue has not received a reapplication (renewal) will be held for sixty (60) days from the date of expiration before being issued to a new applicant.
- (17) Original applications for special license plates for motorcycles and motortricycles filed prior to January 1 of any calendar year shall be treated as applications for special license plates with an expiration month of the coming April. Original applications for special license plates for motorcycles and motortricycles filed after December 31 of any calendar year will be treated as applications for special license plates to be issued in the coming April with an expiration month of the next succeeding April.
 - (A) Example One: Original application filed on December 31, 1999, will result in special license plates which expire in April of 2000.
 - (B) Example Two: Original application filed on January 1, 2000, will result in special license plates issued in April of 2000 with an expiration month of April 2001.
- (18) Original applications for special license plates issued to members of the United States



Congress, Missouri State Senate, Missouri House of Representatives and for the following statewide elected officials: governor, lieutenant governor, secretary of state, state auditor, state treasurer and attorney general, in accordance with section 301.144, RSMo, filed prior to October 1 of any calendar year shall be treated as applications for special license plates with an expiration month of the coming January, while applications filed after the last day of September of any calendar year will be treated as application for special license plates to be issued in the coming January with an expiration month of the next succeeding January.

(A) Example One: Original applications filed on September 30, 2000, will result in special personalized license plates which expire in January 2001.

(B) Example Two: Original applications filed on October 1, 2000, will result in special license plates issued in January of 2001 with an expiration of January 2002.

(19) Reapplications (renewals) for special license plates shall be filed with the Department of Revenue prior to the last day of the month in which they expire.

(20) The director of revenue may recall any special license plate erroneously issued under this rule.

AUTHORITY: sections 301.144, 301.449 and 301.451, RSMo Supp. 1999. Original rule filed Aug. 14, 1978, effective Nov. 13, 1978. Amended: Filed April 11, 1979, effective July 11, 1979. Emergency amendment filed Oct. 30, 1979, effective Nov. 9, 1979, expired Feb. 18, 1980. Amended: Filed Oct. 30, 1979, effective Feb. 11, 1980. Emergency amendment filed March 9, 1982, effective March 19, 1982, expired July 16, 1982. Amended: Filed May 20, 1982, effective Sept. 13, 1982. Amended: Filed Feb. 24, 1984, effective June 11, 1984. Amended: Filed Nov. 18, 1986, effective March 12, 1987. Amended: Filed July 17, 1989, effective Oct. 27, 1989. Amended: Filed Oct. 30, 1989, effective March 26, 1990. Emergency amendment filed Sept. 16, 1991, effective Sept. 26, 1991, expired Jan. 23, 1992. Amended: Filed Sept. 16, 1991, effective Jan. 13, 1992. Amended: Filed Sept. 1, 1995, effective Feb. 25, 1996. Amended: Filed Jan. 31, 2000, effective July 30, 2000.*

**Original authority 301.144, RSMo 1977, amended 1979, 1983, 1984, 1989, 1992, 1993, 1995; 301.449, RSMo 1989, 1995; and 301.451, RSMo 1991, amended 1993, 1995, 1997.*



MISSOURI DEPARTMENT OF REVENUE
MOTOR VEHICLE BUREAU
P.O. BOX 100, JEFFERSON CITY, MO 65105-0100 (573) 526-3669
APPLICATION FOR MISSOURI
PERSONALIZED AND SPECIAL LICENSE PLATES

SEE INSTRUCTIONS ON REVERSE

"ANY FALSE STATEMENT IS A VIOLATION OF THE LAW AND MAY BE PUNISHED BY FINE, IMPRISONMENT, OR BOTH." (301.420 RSMO.)

NAME MUST APPEAR AS SHOWN ON VEHICLE TITLE
OWNER'S NAME
STREET, RR, OR P.O. BOX NUMBER
CITY, STATE, ZIP CODE
CURRENT LICENSE NUMBER
TELEPHONE NUMBER
DO NOT WRITE IN THIS AREA

New Application Adding a Name Dropping a Name (Release of Interest Req) Name Change Only (Same Owner)

CATEGORY OF LICENSE PLATE (PLEASE CHECK WHICH CATEGORY OF LICENSE PLATE YOU NEED)
Passenger (car) Beyond Local 12 Truck Motorcycle
Beyond Local 6 Truck Local 12 Truck
Local 6 Truck Recreational Vehicle
PROFESSIONAL SPORTS TEAM PLATES ONLY
Beyond Local 18 Truck Local 18 Truck

TYPE OF LICENSE PLATE TO BE ISSUED (Proof of eligibility required - see reverse)
TYPE
Regular Personalized (\$15)
Amateur Radio (\$15) Call Letters
Children's Trust Fund (Regular) (\$15)
Children's Trust Fund (Personalized) (\$15)
Collegiate (Personalized) (\$15) College or University
Disabled Person (Personalized) (\$15)
Ducks Unlimited (Personalized) (\$15)
Eastern Star (Personalized) (\$15)
Emergency Medical Services (\$15)
Paramedic Emergency Medical Technician
Firefighter (Regular) (\$15)
Firefighter (Personalized) (\$30)
Fraternal Order of Eagles (Personalized) (\$15)
Helping Schools (Personalized) (\$15)
Knights of Columbus (Personalized) (\$15)
Legislative (\$15)
Lions Club (Regular) (\$15)
Lions Club (Personalized) (\$15)
Masonic Grand Lodge (Personalized) (\$15)
Missouri Jaycee (Regular) (\$15)
Missouri Jaycee (Personalized) (\$30)
Prince Hall (Personalized) (\$15)
Professional Sports Team (Personalized) (\$15)
Kansas City Blades St. Louis Blues
Kansas City Chiefs St. Louis Cardinals
Kansas City Royals St. Louis Rams
Kansas City Wizards
Street Rod (Regular) (\$15)
Street Rod (Personalized) (\$30)
Shuttle Bus (\$15)
Vanpool (\$15)
Other

*APPLICATION MUST BE NOTARIZED

PERSONALIZED PLATE CHOICES (Complete only if applying for personalized plates)
PLEASE USE ALL CAPITAL LETTERS AND SHOW CHOICES IN ORDER OF PREFERENCE. (Please include more than one choice.) Personalized license plates may consist of no more than six characters or six characters plus a dash, space or an apostrophe. Personalized plates displaying an emblem, motorcycle and motortricycle plates may consist of no more than six characters or five characters plus a dash, space or an apostrophe. The wheelchair accessibility symbol is displayed on Disabled Persons plates. The Department of Revenue will not issue plates that contain or suggest profane, obscene or inflammatory words or phrases, those contrary to public policy, or those that conflict with the regular license numbering system.

FIRST CHOICE SECOND CHOICE THIRD CHOICE FOURTH CHOICE FIFTH CHOICE SIXTH CHOICE

LICENSE OFFICE INFORMATION AND SIGNATURE (Must be completed by all applicants)

IMPORTANT: These license plates will not be mailed. Indicate name of license office where plates are to be picked up.
OFFICE OFFICE NUMBER I hereby apply for the personalized or special license plate indicated to be issued to the vehicle owner listed above.
STREET CITY SIGNATURE OF OWNER OR APPLICANT
X

NOTARY INFORMATION (Must be completed if applying for amateur radio, fire department or street rod plates)

NOTARY PUBLIC EMBOSSE OR BLACK RUBBER STAMP SEAL
STATE OF COUNTY (OR CITY OF ST. LOUIS)
SUBSCRIBED AND SWORN BEFORE ME, THIS DAY OF YEAR
NOTARY PUBLIC SIGNATURE MY COMMISSION EXPIRES
NOTARY PUBLIC NAME (TYPED OR PRINTED)
USE RUBBER STAMP IN CLEAR AREA BELOW.

**INSTRUCTIONS TO APPLICANT**

Applications must be completed, signed and submitted with the fee noted on the front of the application. This annual fee is in addition to the regular registration fee set by law and is payable upon renewal. Depending on the type of license plates requested, additional documentation may be required as noted below. Make check or money order (do not send cash) payable to the Missouri Department of Revenue and forward with this application to: MISSOURI DEPARTMENT OF REVENUE, MOTOR VEHICLE BUREAU, PERSONALIZED LICENSE PLATE SECTION, P.O. BOX 100, 301 W. HIGH ST., JEFFERSON CITY, MO 65105-0100. If you have questions, call (573) 526-3669.

Special license plates are issued only to those vehicles that are titled and registered in Missouri. Any special plate issued may be adapted to include the international wheelchair accessibility symbol and the word "DISABLED"

The pink copy of the validated DOR-1716 is proof your application for license plates has been received and approved by the Department of Revenue. If you requested personalized plates, they are being manufactured. You will receive additional notification in approximately two (2) to four (4) weeks when your license plates have been forwarded to the license office you indicated on the front of this application.

NOTE: IF PERSONALIZED LICENSE PLATES ARE NOT RENEWED WITHIN 60 DAYS OF EXPIRATION THEY MAY BE REISSUED TO ANOTHER APPLICANT.

AMATEUR RADIO PLATES: Your notarized signature on the front of this application constitutes a sworn statement that you hold an unrevoked and unexpired amateur radio license and that the call letters indicated on the front of this application are the official call letters issued by the FCC. You must submit a copy of your Federal Communications License with this application.

DISABLED PERSON PLATES: A signed physician's statement, DOR-1776, from a licensed physician, chiropractor, podiatrist, or optometrist must be submitted with your application.

FIREFIGHTER PLATES: Your notarized signature on the front of this application constitutes a sworn statement that you are a director of a fire protection district, or are compensated, partially compensated or a volunteer member of any fire department, fire protection district or voluntary fire protection association in Missouri. You further affirm that if you resign, are removed, or otherwise terminate association with the fire department, you will return your special license plates to the Department within fifteen (15) days.

STREET ROD PLATES: Your notarized signature on the front of this application constitutes a sworn statement that this vehicle was manufactured in 1948 or before and has been modified for safe road use including but not limited to modification to the drive train, suspension, brake system, and safety or comfort apparatus and which is not owned solely as a collector's item and which is not or intended to be used solely for exhibition and educational purposes. This registration is not transferable. If the vehicle is disposed of, plates must be returned to the Department of Revenue for cancellation.

MISSOURI JAYCEES PLATES: You must submit proof of membership in the form of a membership identification card.

CHILDREN'S TRUST FUND, COLLEGIATE, DUCKS UNLIMITED, EASTERN STAR, EMERGENCY MEDICAL SERVICES, FRATERNAL ORDER OF EAGLES, HELPING SCHOOLS, KNIGHTS OF COLUMBUS, LIONS CLUB, MASONIC GRAND LODGE, PRINCE HALL, AND PROFESSIONAL SPORTS TEAM: You must submit an Emblem/Logo Use Authorization Statement from the organization, college or university as proof of a donation.

NOTE: PROFESSIONAL SPORTS TEAM LICENSE PLATE: The Department of Revenue must receive a minimum of one hundred applications for each specific professional sports team before producing the license plates.



12 CSR 10-23.110 Hearing Held Pursuant to Section 301.257, RSMo
(Rescinded April 29, 1991)

AUTHORITY: section 301.257, RSMo 1986. Original rule filed Nov. 5, 1982, effective Feb. 11, 1983. Emergency amendment filed July 3, 1985, effective July 13, 1985, expired Nov. 10, 1985. Amended: Filed July 3, 1985, effective Oct. 11, 1985, Emergency amendment filed June 12, 1986, effective June 22, 1986, expired Oct. 20, 1986. Amended: Filed June 12, 1986, effective Sept. 26, 1986. Rescinded: Filed Nov. 15, 1990, effective April 29, 1991.

12 CSR 10-23.120 Business Records of Manufacturers, Dealers and Boat Dealers
(Rescinded December 3, 1992)

AUTHORITY: section 301.251, RSMo 1986. Original rule filed April 25, 1983, effective Sept. 11, 1983. Amended: Filed May 27, 1986, effective Aug. 25, 1986. Rescinded: Filed April 23, 1992, effective Dec. 3, 1992.

William R. Newmann, d/b/a Goodfellow Auto Sales & Salvage, Inc. v. Director of Revenue, Case No. RV-86-0286 (A.H.C. 8/30/88). The Administrative Hearing Commission found that petitioner failed to maintain complete records and files on motor vehicles and motor vehicle parts acquired for resale in the business office at the registered location during normal business hours and that suspension of its auto salvage dealer's license was proper.

12 CSR 10-23.130 Legal Name on Title Application

PURPOSE: This rule sets forth the requirement of using the full legal name when making application for a motor vehicle or trailer certificate of title.

(1) Any person(s) making application for a certificate of title for a motor vehicle or trailer must make the application using his/her or their full legal name. For the purpose of section 301.190, RSMo, the legal name is deemed to be the name that appears on that person's Missouri operator's or chauffeur's license.

(2) The legal name for any business making application for a certificate of title for a motor vehicle or trailer is deemed to be the name or the fictitious name as registered with the secretary of state.

*AUTHORITY: section 301.190, RSMo 1986. *Original rule filed Feb. 3, 1984, effective May 11, 1984.*

**Original authority: 301.190, RSMo 1939, amended 1947, 1965, 1981, 1983, 1984, 1985, 1986, 1986, 1987, 1988, 1989, 1990.*

12 CSR 10-23.140 Motor Vehicle Title Services

PURPOSE: This rule establishes the requirements that must be met for registration as a title service agent.

(1) Motor vehicle title service agents registering pursuant to section 301.114.2., RSMo shall file an application with the Department of Revenue on a form provided by the director of revenue. The application shall be filed annually together with the following:

(A) Proof of registration with the Office of the Secretary of State, either Certificate of Incorporation or fictitious name registration, if required;

(B) A corporate surety bond on a form approved by the director of revenue. The bond requirements are—

1. The amount of the bond must be twenty-five thousand dollars (\$25,000);

2. The bond must be executed in the name of the State of Missouri for the benefit of any aggrieved party. The proceeds are to be payable to the aggrieved party upon receipt by the director of a final judgment from a court of competent jurisdiction against the title service agent;

3. The effective date for the bond must be on or before the date the application is received by the motor vehicle bureau;

4. The bond must state that it is conditioned upon the applicant's compliance with the provisions of the statutes applicable to all requirements for the lawful obtaining or receiving of certificates of ownership for motor vehicles;

5. The bond must state that it is an indemnity bond for loss sustained by any person by reasons of an act of the title service agent when that act could constitute grounds for suspension or revocation of the title service agent's registration; and

6. The bond must state that in the event of cancellation by the surety, the Department of Revenue will receive notice of cancellation prior to the cancellation;

(C) Address where business is to be conducted (not a post office box) and the established business hours; and

(D) Registration fee.

(2) A title service agent must file a separate application and shall be issued a separate license for each location owned and operated by the agent.

(3) All registrations expire on June 30 of each year and applications for renewal must be filed in a timely manner to assure registration for the year beginning July 1.

(4) Any title service agent who changes the site of either the principal or a branch location must comply with all provisions of section 301.114, RSMo before the application may be accepted.

(5) Whenever a title service agent is no longer entitled to registration pursuant to section 301.114, RSMo through voluntary cessation of business, abandonment of the registered place of business, suspension of registration, sale of a business, declaration of bankruptcy or for any other reason, the title service agent immediately shall surrender his/her license to the director of revenue regardless of the unexpired time remaining in the registration period applicable to that license. No portion of the registration fee will be refunded.

(6) The agent must maintain reasonable business hours to allow contact by any authorized representative of the department, member of the Missouri State Highway Patrol or any authorized peace officer. Reasonable business hours will be considered to be 9:00 a.m. to 4:00 p.m., four (4) days a week. If the title service is closed, the agent, by notice, must inform the public of a reasonable method of making appointments and the hours during which the agent will be present. An agent may make written application to the Department of Revenue for approval of more limited hours of operation than those required in this section and may operate during the hours upon written approval by the Department of Revenue.

(7) Any changes in the application information must be reported immediately to the motor vehicle bureau.

*AUTHORITY: section 301.114, RSMo 1986. *Original rule filed Sept. 10, 1984, effective Jan. 12, 1985.*

**Original authority: 301.114, RSMo 1984.*



MISSOURI DEPARTMENT OF REVENUE
MOTOR VEHICLE BUREAU

APPLICATION FOR TITLE SERVICE CERTIFICATE OF REGISTRATION

Valid only for business address shown below (301.114 RSMo)

VALIDATION ONLY:

Title Service Name: _____ Telephone: () _____

Street: _____ City: _____

State: _____ County: _____ Zip Code: _____

Type of Ownership (Check One):

A. Individual B. Partnership C. Corporation

D. If applicable, papers of incorporation filed in which state? _____

List all owners below: (If corporation, indicate principal officers)

1.	_____	_____	_____	_____	_____	_____	()
	Full Legal Name	Birthdate	Street	City	State	Zip Code	Home Telephone
2.	_____	_____	_____	_____	_____	_____	()
	Full Legal Name	Birthdate	Street	City	State	Zip Code	Home Telephone
3.	_____	_____	_____	_____	_____	_____	()
	Full Legal Name	Birthdate	Street	City	State	Zip Code	Home Telephone
4.	_____	_____	_____	_____	_____	_____	()
	Full Legal Name	Birthdate	Street	City	State	Zip Code	Home Telephone

I do solemnly verify that the concern named herein is a bona fide title service business, and that I do have the authority to make the statements contained and to sign this application.

Signature of Authorized Applicant

Date

IMPORTANT

1. A title service agent must file a separate application and shall be issued a separate license for each location owned and operated by such agent.
2. Copies of the following must be submitted with application for approval of registration:
 - a. Proof of registration with the Secretary of State, either Certificate of Incorporation, or Fictitious Name Registration; and,
 - b. a corporate surety bond in the amount of twenty-five thousand dollars (\$25,000.00).
3. Whenever a title service agent is no longer entitled to registration pursuant to Section 301.114, for whatever reason, the title service agent shall immediately surrender his license to the Director of Revenue.

"Any false statement in this application is a violation of the law and may be punished by fine or imprisonment or both" (301.420 RSMo).

DISTRIBUTION: White Copy — Office, Pink Copy — Applicant, Yellow Copy — Audit

DOR-2509 (7-84)



Motor Vehicle Bureau
Division of MV/DL
Post Office Box 3325
Jefferson City, MO 65105-3325

STATE OF MISSOURI
DEPARTMENT OF REVENUE

Dear Title Service Applicant:

Enclosed is your title service registration renewal application for the 1990-1991 registration year. Please read and follow the instructions very carefully to prevent the rejection of your application and interruption of your business.

All title service registrations expire June 30th of each year. To guarantee that your application is approved before the June 30th expiration date, please submit the application and all requirements by June 23, 1990.

If you have any questions, please call (314) 751-4469.

Thank you for your immediate attention to these matters.

CENTRAL BRANCH SECTION
Special Registration Unit
5506 (4-10-90)



MISSOURI TITLE SERVICE REGISTRATION INSTRUCTIONS

Note: Title Service Registrations Expire June 30th of Each Year
Renewals Should Be Submitted By June 23, 1990

Who Must Register?

Missouri law (301.114 RSMo.) requires any person who carries on or conducts a business, the purpose of which is to act as an agent for a fee in obtaining a certificate of ownership of a motor vehicle, to register as a motor vehicle title service agent.

Registration Requirements

Any person who registers as a Missouri title service agent must submit the following (A separate application and the required documents must be submitted for each location operated):

1. Application, DOR-2509 (7-84) - must be completed in full and signed by the owner, partner or corporate officer listed on the application;
2. Corporate Surety Bond - A corporate surety bond in the amount of twenty-five thousand dollars (\$25,000.00). Attached are the bond requirements and a sample bond that may be used. If the bond is due to expire, a notarized letter or form signed by the bonding company stating the bond is still in full force and effect must be submitted. The letter must indicate an expiration date or state that the bond is non-expiring, and shall in all cases state that the Department of Revenue will be notified in case of cancellation by either party.
3. Fees - A check or money order for the \$50.00 annual registration fee made payable to the Missouri Department of Revenue (Do not send cash).
4. Missouri law (301.114 RSMo.) requires all title service applicants to be of good moral character. Good moral character is determined through a criminal record check made by the Missouri State Highway Patrol of all owners, partners, or principal officers (if a corporation) listed on the application.

The required documents must be mailed to the address shown below. Failure to submit any of the required documents or fees as herein provided will result in the rejection of the application and cause a delay in registration. Mail all applications to the following address: Department of Revenue, Motor Vehicle Bureau, Special Registration Unit, P.O. Box 3325, Jefferson City, Missouri 65105-3325. Applications which are hand delivered will not be approved the same day they are delivered.

CORPORATE SURETY BOND

Missouri law requires that every applicant for a Motor Vehicle Title Service license shall furnish, at the time of application, a corporate surety bond in the penal sum of \$25,000.00. The bond shall be on a form provided by the Director of Revenue. The requirements of the bond are as follows:

1. The bond must be executed in the name of the State of Missouri for the benefit of any aggrieved party.
2. The title service name must be listed as principal of the bond.
3. The effective date of the bond must be on or before the date of the application for title service license.
4. The bond must state that it is conditional upon the applicant's compliance with the provisions of the statutes applicable to all requirements for the lawful obtaining or receiving of certificates of ownership for motor vehicles.
5. The bond must state that it is an indemnity bond for loss sustained by any person by reason of an act of the title service, when that act could constitute grounds for suspension or revocation of the title service's registration.
6. The amount of the bond must be \$25,000.00 and must specify that the liability of the surety bond shall in no event exceed \$25,000.00.
7. The bond may or may not state that it is payable to the aggrieved party only after final judgment of a Missouri Court against the title service.
8. The bond must indicate an expiration date or state that it is a non-expiring bond, and shall, in all cases, state that the Department of Revenue will be notified in case of cancellation by either party.
9. The principal (title service agent) must sign the bond and have his signature witnessed or notarized.
10. The authorized agent of the bonding company must sign the bond and have his signature witnessed or notarized.

If a completed bond form does not accompany the title service's application for registration, the application will be rejected. The attached sample bond meets all the requirements set forth by Missouri law and may be used as a sample.



SAMPLE BOND

MISSOURI TITLE SERVICE

KNOW ALL MEN BY THESE PRESENT, that we _____
 _____ Title Service Name
 as Principal, and _____, a corporation organized and
 _____ Bonding Company
 existing under the laws of the State of _____, having its
 principal place of business at _____, as
 Surety, are held and firmly bound unto the State of Missouri, in the penal sum
 of Twenty-Five Thousand Dollars (\$25,000.00) for the payment of which, well and
 truly to be made, we bind ourselves, our heirs, executors, administrators,
 successors and assigns, jointly and severally, firmly by these present.

THE CONDITION of the above obligation is such that WHEREAS the Principal
 has applied for the issuance of a Motor Vehicle Title Service license and
 presents this bond in accordance with said statute.

NOW, THEREFORE, if the aforesaid Principal shall faithfully comply with the
 provisions of the State of Missouri statutes applicable to all requirements for
 the lawful obtaining or receiving of certificates of ownership for
 motor vehicles, and shall indemnify any person dealing or transacting business
 with the principal for any loss sustained by any person by reason of the acts of
 principal provided such acts of Principal constitute grounds for suspension or
 revocation of Principal's registration, then this obligation to be void;
 otherwise, to remain in full force and effect.

The aggregate liability of the Surety of all persons shall, in no event,
 exceed the amount of this bond during any one license year.

The bond shall be effective _____, 19____ and shall
 expire _____, 19____ (Bond can be listed as "non-expiring").

This bond may be cancelled by the Surety giving written notice to the
 Principal and Missouri Director of Revenue, stating the date of cancellation,
 which in no event shall be less than thirty (30) days after receipt of said
 notice by the Director of Revenue; however, the Surety shall remain liable for
 any and all acts of the Principal covered by this bond up to the date of
 cancellation.

Dated this _____ day of _____, 19____.

WITNESS TO PRINCIPAL'S SIGNATURE

 Signature

 Signature of Title Service (Principal)
 (Seal)

WITNESS TO SURETY'S SIGNATURE

 Signature

 Signature of Bondsman (Surety) (Seal)



12 CSR 10-23.150 Administrative Hearing Held Pursuant to Section 301.119, RSMo

PURPOSE: This rule establishes the procedures that will be utilized by the director and title service agents for compliance with section 301.119, RSMo.

(1) A title service agent receiving a notice of revocation/suspension for failure to satisfy the requirements of state law must request a hearing by the date stated on the notice of revocation/suspension. Failure to request the hearing by that date will be considered a waiver of the right to an administrative hearing and will make final, for the purposes of review, the director's decision.

(2) The date of the United States postmark shall be deemed the date of filing. If the request for hearing is delivered by hand, the date of filing shall be deemed to be the date received by the director of revenue or his/her official representative. If any date for performing any act falls on a Saturday, Sunday or legal holiday in this state, the act shall be considered timely provided it is performed on the next succeeding business day.

(3) Hearings will be held in Jefferson City, Missouri. Cases will be placed on the administrative docket in the order in which they are received.

(4) Parties requesting hearings will be notified by first class mail of the date and time of the hearing. A copy of the notice will be sent to the attorneys of record and the parties involved.

(5) Parties requesting hearings will be allowed one (1) continuance at the discretion of the hearing officer, provided good cause is shown. All requests for continuances shall be made in writing, state good cause for the continuance and be signed and verified by the party making the requests or his/her attorney or authorized representative. All requests for continuance must be filed not later than six (6) days prior to the date of the scheduled hearing. The following events or conditions shall constitute good cause to continue a hearing:

(A) Death of a party, representative, or an attorney of a party, or a witness to an essential fact;

(B) Incapacitating illness of a party, or representative, or attorney of a party or witness to an essential fact. The request must contain a written statement by an attending physician reciting the nature and probable duration of the illness; and

(C) Unavailability of a party, representative or attorney or material witness due to an unavoidable emergency.

(6) Cases under section 301.119, RSMo shall be considered contested cases as that term is defined in Chapter 536, RSMo.

(7) Hearing procedures are as follows:

(A) The director of revenue or his/her representative shall state to the requesting party that the director has determined that the title service agent has failed to comply with the provisions of Chapter 301, RSMo and the basis for this decision by the director;

(B) The requesting party may present any new facts which s/he feels may show compliance with the applicable provisions of Chapter 301, RSMo;

(C) Parties may present testimony by affidavit. Affidavits may be filed at the time of hearing or after notice of setting of the hearing. Parties will submit the original and three (3) copies of affidavits;

(D) Failure to appear at the hearing at the stated time will make the decision of the director final as of that date; and

(E) The provisions of Chapter 536, RSMo shall apply to hearings held pursuant to section 301.119, RSMo.

(8) The director shall make findings of fact and conclusions of law and enter his/her decision. All parties will be mailed a copy of the findings of fact and conclusions of law. No decision will be given at the time of the hearing.

(9) The effective date of the director's decision shall be the date set out in the notice of revocation/suspension or the date set in the hearing decision letter, whichever date is later.

(10) Parties may present briefs of law at the time of the hearing.

AUTHORITY: section 301.119, RSMo 1986. Original rule filed Sept. 10, 1984, effective Jan. 12, 1985.*

**Original authority: 301.119, RSMo 1984.*

12 CSR 10-23.160 Good Moral Character of Motor Vehicle Dealers, Manufacturers, Boat Dealers, Salvage Dealers and Title Service Agents

PURPOSE: The director of the Department of Revenue is charged with the responsibility of determining that applicants for registration

as motor vehicle dealers, salvage dealers and title service agents are of good moral character. This rule establishes the guidelines which will be used to determine if the applicant is eligible for registration.

(1) Except with a showing of evidence to the contrary, the following will be considered *prima facie* evidence on which the registration of a motor vehicle dealer, manufacturer, boat dealer, salvage dealer or title service agent will be denied because of lack of good moral character if the applicant:

(A) Has ever been convicted in any federal or state court of a felony relating to the acquisition or transfer of motor vehicles, trailers, motor vehicle parts or boats;

(B) Within five (5) years preceding the application, has been convicted in any federal or state court of a felony, within the last three (3) years, or has been convicted in any federal or state court of a misdemeanor relating to the acquisition of or transfer of motor vehicles, trailers, motor vehicle parts or boats; and

(C) Within three (3) years preceding the application, has been convicted in any federal or state court of a misdemeanor, or has shown contempt of laws in civil or administrative proceedings; or has had a motor vehicle dealer registration, manufacturer registration, boat dealer registration, salvage dealer registration or title service agent registration revoked in this or another state and has demonstrated through conduct since the date of the occurrence that no substantial improvement in character or reliability has occurred. A determination by the director of revenue that conduct subsequent to the occurrence in question demonstrated a failure to improve character or reliability will be made only following a notice to the applicant and a subsequent hearing before the director of revenue or his/her representative.

(2) Any dealer or applicant who receives notice of denial or revocation and desires to contest the *prima facie* of the fact(s) recited in subsection (1)(A) or (B) may request a hearing for the purpose of showing substantial rehabilitation or improvement in character sufficient to rebut the presumption created by the cited subsections. Request for a hearing should be submitted to the Director, Motor Vehicle and Driver's Licensing Division, P.O. Box 629, Jefferson City, MO 65105.

AUTHORITY: sections 301.114, 301.221 and 301.251, RSMo 1986. Original rule filed Oct. 15, 1984, effective Feb. 11, 1985.*



Amended: Filed June 4, 1986, effective Aug. 25, 1986.

**Original authority 301.114, RSMo 1984; 301.221, RSMo 1979, amended 1986; and 301.251, RSMo 1981, amended 1984, 1985, 1986.*

12 CSR 10-23.170 Registration of Corporation Motor Vehicles/Emission System Inspection Areas

(Rescinded November 30, 2007)

AUTHORITY: sections 137.095, 301.025, 301.130 and 307.366, RSMo 1986. Original rule filed Jan. 8, 1985, effective June 13, 1985. Rescinded: Filed May 23, 2007, effective Nov. 30, 2007.

12 CSR 10-23.180 Replacement Vehicle Identification Plates

PURPOSE: This rule clarifies the issuance of replacement vehicle identification number plates stamped with the original vehicle identification number assigned by the manufacturer of the motor vehicle or trailer by the Department of Revenue.

(1) Upon certified application, the Department of Revenue may authorize the issuance of one (1) metal replacement vehicle identification number (VIN) plate with the original VIN stamped on the plate. The plate will be designed by the department in order to distinguish the replacement plate from the original plate. Before the issuance of any replacement plate, a physical inspection of the vehicle to determine the true and complete VIN must be made by an officer of a law enforcement agency approved by the Department of Revenue for that purpose. The inspecting officer shall certify the inspection in the appropriate place on the application and may retain a copy.

(2) After the replacement VIN plate is issued, the Department of Revenue will forward a copy of the application for replacement VIN (see 12 CSR 10-23.426) plate accompanied by the replacement plate itself to the original inspecting law enforcement agency who will make contact with the vehicle owner.

(3) The attachment of the replacement plate to the vehicle must be made by or under the supervision of the original inspecting law enforcement officer. A certification attesting to the attachment of the plate shall be made on a copy of the application by the officer and the copy will then be returned by the officer to the Department of Revenue. No replace-

ment VIN plate other than one provided by the Department of Revenue shall be affixed to any motor vehicle or trailer.

(4) The fee for the replacement VIN plate will be seven dollars and fifty cents (\$7.50).

*AUTHORITY: section 301.300, RSMo 1986. *Original rule filed July 31, 1985, effective Nov. 28, 1985.*

**Original authority: 301.300, RSMo 1939, amended 1941, 1947, 1981, 1984, 1988, 1990.*

12 CSR 10-23.185 Obscene License Plates

PURPOSE: This rule establishes the guidelines for issuing personalized motor vehicle license plates.

(1) Language or symbols which are obscene or profane are not protected by the United States or Missouri Constitution. The language or symbols shall not be allowed on any personalized motor vehicle license plate issued under the provisions of section 301.144, RSMo. In determining whether or not requests for personalized motor vehicle license plates contain language or symbols which are obscene or profane, the Department of Revenue will use the standards in section (2).

(2) The following terms, as used in this rule, shall be defined as follows:

(A) Obscene—Language or symbols which represent or describe ultimate excretory functions or sexual acts in a patently offensive manner or make lewd reference to the male or female sexual organs and appeal to the prurient interests of the average person applying contemporary community standards (see *Miller v. California*, 415 U.S. 15, 93 S.Ct. 2607 (1973)). Prurient interests, as used in this definition, shall mean shameful or morbid interest in nudity, sex or excretion that goes substantially beyond customary limits or candor in description or representation of these matters (see *Haldeman v. United States*, C.A. Kan., 340 F2d 59 (10th Cir., 1965)); and

(B) Profane—Language or symbols which are irreverent or contemptuous of things regarded as sacred or that imply divine condemnation (see *Baker v. State*, 16 Ariz. App. 463, 494 P2d, 68 (1972) and *Duncan v. United States*, 48 F2d 128 (9th Cir., 1931)).

(3) No motor vehicle license plate will be issued by the Department of Revenue if the language or symbols on the plate are obscene or profane. In order to make this determina-

tion, the Department of Revenue will look to the way the average person applying contemporary community standards would view the license plate. Factors which the Department of Revenue may consider in this regard include, but are not limited to:

(A) An explanation by the registrant as to why s/he chose particular language or symbols to be on his/her personalized motor vehicle license plate;

(B) Complaints from the public regarding a license plate with the same letters, numbers or symbols as that requested or held by the registrant;

(C) Complaints from the public regarding a license plate with similar letters, numbers or symbols as that requested or held by the registrant;

(D) Dictionary definitions of the language or symbols requested by the registrant; and

(E) Information from other states regarding motor vehicle plates which have not been issued by them because they found them to be obscene or profane.

(4) The Department of Revenue shall recall any personalized motor vehicle license plate which it has already issued if it determines that a plate is obscene or profane.

*AUTHORITY: section 301.144, RSMo Supp. 1991. *Original rule filed Jan. 6, 1986, effective April 11, 1986. Emergency amendment filed Jan. 2, 1992, effective Jan. 12, 1992, expired May 10, 1992. Amended: Filed Jan. 2, 1992, effective May 14, 1992.*

**Original authority: 301.144, RSMo 1977, amended 1979, 1983, 1984, 1989.*



MISSOURI DEPARTMENT OF REVENUE
MOTOR VEHICLE BUREAU
**APPLICATION FOR REPLACEMENT OF VEHICLE
IDENTIFICATION NUMBER PLATE**

SEE INSTRUCTIONS ON REVERSE			
VALIDATION ONLY			
REGISTERED OWNER (LAST, FIRST, MIDDLE)			
STREET, R.R. OR P.O. BOX NUMBER			COUNTY
CITY, STATE, ZIP CODE			TELEPHONE NUMBER
YEAR	MAKE	BODY STYLE	VEHICLE IDENTIFICATION NUMBER
MISSOURI TITLE NUMBER		LICENSE NUMBER	LOSS OF VIN PLATE REPORT TO: DATE
REASON REQUIRED <input type="checkbox"/> LOST <input type="checkbox"/> STOLEN <input type="checkbox"/> MUTILATED <input type="checkbox"/> DESTROYED			
I certify that the statements above are true and that I am the registered owner of the above described vehicle.			
NOTARY SEAL		APPLICANT'S SIGNATURE	
		SWORN TO AND DESCRIBED BEFORE ME THIS	
		DAY OF _____, 19____	
		NOTARY PUBLIC	COMMISSION EXPIRATION
I certify that on _____ ^{DATE} I physically inspected the above described vehicle after the applicant provided satisfactory proof of ownership and found the vehicle identification number to be:			
LAW ENFORCEMENT AGENCY			FILE NUMBER
INSPECTING OFFICER			BADGE NUMBER
I certify that on _____ ^{DATE} I did affix the replacement vehicle identification plate number _____ ^{INSERT NUMBER} issued by the Department of Revenue to the above vehicle.			
LAW ENFORCEMENT AGENCY			
LAW ENFORCEMENT OFFICER			BADGE NUMBER

MO 860-0315 (9-86)

DISTRIBUTION: WHITE, YELLOW, PINK - DEPT. OF REVENUE
GOLDENROD - INSPECTING LAW ENFORCEMENT AGENCY

DOR-923 (9-86)



12 CSR 10-23.190 Temporary Permits Sold by a Registered Missouri Motor Vehicle Dealer

(Moved to 12 CSR 10-26.180)

12 CSR 10-23.200 Nonnegotiable Certificate of Title to a Motor Vehicle or Trailer

(Rescinded September 9, 1993)

AUTHORITY: sections 301.010, 301.190 and 301.300, RSMo Supp. 1990. Original rule filed Jan. 17, 1986, effective May 29, 1986. Amended: Filed Nov. 12, 1991, effective March 9, 1992. Rescinded: Filed March 24, 1993, effective Sept. 9, 1993.

12 CSR 10-23.210 Congressional Medal of Honor License Plates

PURPOSE: This rule clarifies procedures for issuance of Congressional Medal of Honor license plates.

(1) Congressional Medal of Honor license plates are Missouri license plates containing letters or numbers or combinations of letters and numbers which may be established by the director of revenue.

(2) The license plates shall bear the words CONGRESSIONAL MEDAL OF HONOR in blue lettering on two (2) lines with letters approximately one inch (1") in height on a white background. Immediately to the left of these words shall appear a one (1) or two (2) digit number. The upper left-hand corner of the plate will bear a reproduction of the Congressional Medal of Honor in gold. On the top of the license plate shall appear the words MISSOURI and JUL.

(3) Congressional Medal of Honor license plates will be issued only to recipients of the Congressional Medal of Honor and may be issued to any motor vehicle other than a commercial motor vehicle licensed for more than twelve thousand pounds (12,000 lbs.).

(4) Congressional Medal of Honor license plates shall be issued only to motor vehicles which are owned solely or jointly by recipients of the medal.

(5) Any person desiring to obtain Congressional Medal of Honor license plates must make application for the set of two (2) plates.

(6) Each initial application for Congressional Medal of Honor plates shall be submitted to the Department of Revenue, P.O. Box 100,

Jefferson City, MO 65105 and shall be accompanied by a letter from the United States Veterans Administration verifying the person was a recipient of the Congressional Medal of Honor. Upon approval, Congressional Medal of Honor license plates will be issued from the Motor Vehicle Bureau Central Office. Subsequent annual renewal may be accomplished at any branch or fee agent office statewide.

(7) Applicants for Congressional Medal of Honor license plates shall be required to comply with all Missouri laws and rules relating to the titling and registration of motor vehicles.

(8) Applications for renewal of Congressional Medal of Honor license plates shall be filed with the Department of Revenue prior to the last regular work day of July each year.

(9) Each person qualifying for a Congressional Medal of Honor license plate may license only one (1) motor vehicle with a Congressional Medal of Honor license plate.

(10) There shall be no fee charged for a Congressional Medal of Honor license plate.

AUTHORITY: section 301.145, RSMo 1986. Original rule filed Jan. 22, 1986, effective May 11, 1986. Amended: Filed Nov. 13, 1986, effective Feb. 28, 1987.*

**Original authority: 301.145, RSMo 1986.*

12 CSR 10-23.220 Motor Vehicle Fee and Tax Refund Requests

(Rescinded November 30, 2007)

AUTHORITY: section 144.270, RSMo 1986. Original rule filed March 3, 1986, effective June 28, 1986. Amended: Filed Nov. 18, 1986, effective March 12, 1987. Rescinded: Filed May 23, 2007, effective Nov. 30, 2007.

12 CSR 10-23.230 Legal Sale of Motor Vehicle or Trailer

PURPOSE: This rule clarifies that, as of August 28, 1989, the form of warranty prescribed by the director of revenue for assignments of title to motor vehicles does not require acknowledgment of the transferor's signature by a notary public. In addition, this rule clarifies that assignments of title made on or after August 28, 1989, which do not include a notarial acknowledgment of the transferor's signature, are not procedurally defective.

(1) Any assignment of a motor vehicle or trailer certificate of title made on or after August 28, 1989, and before February 11, 1991, is not procedurally defective by reason of the transferor's signature not being acknowledged by a notary public.

(2) Beginning on August 28, 1989, an assignment of a certificate of title does not require an acknowledgment of the transferor's signature by a notary public. As of that date, the form of warranty of title prescribed by the director of revenue for the proper assignment of certificate of title pursuant to section 301.210, RSMo removed any requirement that the transferor's signature be notarized.

AUTHORITY: section 301.210, RSMo 1986. Original rule filed March 3, 1986, effective June 28, 1986. Emergency rescission filed Jan. 3, 1991, effective Jan. 13, 1991, expired May 13, 1991. Rescinded: Filed Jan. 3, 1991, effective June 10, 1991. Emergency rule filed Feb. 1, 1991, effective Feb. 11, 1991, expired June 10, 1991. Readopted: Filed Feb. 1, 1991, effective June 10, 1991.*

**Original authority: 301.210, RSMo 1939, amended 1947, 1984, 1991.*

12 CSR 10-23.240 Recording of Mileage on an Application for Certificate of Title

(Rescinded July 8, 1991)

AUTHORITY: sections 301.190, 301.210 and 407.536, RSMo 1986. Original rule filed March 3, 1986, effective June 28, 1986. Amended: Filed Dec. 2, 1986, effective March 12, 1987. Rescinded: Filed Feb. 15 1991, effective July 8, 1991.

12 CSR 10-23.250 Registration and Classification of Commercial Motor Vehicles

PURPOSE: This rule sets forth the requirements for the registration and classification of commercial motor vehicles.

(1) The intended usage of a motor vehicle shall determine how a vehicle is to be registered unless the registration is otherwise defined by statute. An applicant shall designate at the time of registration the type of usage for which the vehicle shall be principally used.

(2) A commercial motor vehicle is a motor vehicle designed for or regularly used for carrying freight and merchandise or more than eight (8) persons, excepting vanpools or shuttle buses. Commercial use of the vehicle



shall be presumed where the vehicle is regularly used for the carrying of freight or persons for more than fifty percent (50%) of the driving time or mileage of the vehicle.

(3) The registrant of a van, truck or station wagon who registers the vehicle as non-commercial shall provide the department with a notarized affidavit that the commercial use of the motor vehicle comprises less than fifty percent (50%) of the use of the vehicle.

AUTHORITY: sections 301.010, 301.020 and 301.030, RSMo 1986. Original rule filed March 3, 1986, effective June 28, 1986.*

**Original authority: 301.010, RSMo 1939, amended 1945, 1949, 1951, 1969, 1974, 1979, 1980, 1983, 1983, 1985, 1986, 1986, 1987, 1988, 1989; 301.020, RSMo 1939, amended 1943, 1945, 1949, 1957, 1969, 1985, 1986, 1988, 1988, 1989; and 301.030, RSMo 1947, amended 1951, 1965, 1974, 1983, 1986.*

12 CSR 10-23.255 Issuance of New and Replacement Vehicle Identification Numbers

PURPOSE: This rule clarifies the issuance of a Department of Revenue vehicle identification number to motor vehicles and trailers which were never assigned a vehicle identification number plate by their manufacturer; have had a number destroyed, removed, covered or altered; or were reconstructed with various major component parts of other motor vehicles or trailers which have conflicting or different vehicle identification numbers.

PUBLISHER'S NOTE: The secretary of state has determined that the publication of the entire text of the material which is incorporated by reference as a portion of this rule would be unduly cumbersome or expensive. This material as incorporated by reference in this rule shall be maintained by the agency at its headquarters and shall be made available to the public for inspection and copying at no more than the actual cost of reproduction. This note applies only to the reference material. The entire text of the rule is printed here.

(1) Upon certified application, the department may authorize the issuance of one (1) adhesive vehicle identification number (VIN) known as a DR number which shall be affixed by authorized law enforcement in an upright position to the inside facing of the driver's door adjacent to the number it is replacing on a motor vehicle; on the front fork of a motorcycle; or in a prominent, upright position on the left side of the tongue

of a trailer; which shall serve as the VIN of the motor vehicle or trailer.

(2) The Department of Revenue (department) shall require an inspection before issuing a DR number to a motor vehicle by an officer of a law enforcement agency approved by the department. The inspecting officer shall certify the inspection on a Vehicle Examination Certificate provided by the department. If the Vehicle Examination Certificate indicates conflicting VINs for the public VIN and the police VIN, and at least three (3) or more new or used major component parts have been used in reconstructing the vehicle, the department will issue a DR number for the inspecting officer to affix to the motor vehicle as described in section (1). If a DR number is required but the applicant has not rebuilt or reconstructed the vehicle, the inspection may be completed on an Application for Vehicle/Trailer Identification Number Plate or Verification. The Vehicle Examination Certificate (revised 4-04) and the Application for Vehicle/Trailer Identification Number Plate or Verification (published 4-06), which have been incorporated by reference, are published by the Missouri Department of Revenue, PO Box 100, Jefferson City, MO 65105-0100. These forms do not include any amendments or additions to the revision/publication dates shown. The Vehicle Examination Certificate is available at all contract offices and the department's central office, or by mailing a written request to the Missouri Department of Revenue, PO Box 100, Jefferson City, MO 65105-0100. The Application for Vehicle/Trailer Identification Number Plate or Verification is available at all contract offices and the department's central office, or may be ordered at <http://www.dort.mo.gov/mvdl/formorder/> or by mailing a written request to the Missouri Department of Revenue, PO Box 100, Jefferson City, MO 65105-0100.

(3) Before issuance of a DR number to the owner of a manufactured trailer, the need for a DR number must be established through inspection of the trailer by an officer of a law enforcement agency approved by the department. The inspecting officer shall certify the inspection on an Application for Vehicle/Trailer Identification Number Plate or Verification provided by the department. If the manufactured trailer does not have a VIN, the department will issue, upon certified application for title by the owner, a DR number for the trailer. The DR number shall be affixed by authorized law enforcement as described in section (1).

(4) If an inspection of a motor vehicle or trailer reveals the public number has been destroyed, removed, covered, altered, or defaced but the confidential number assigned by the manufacturer can be located, the department will issue a replacement number containing the original VIN assigned by the manufacturer.

AUTHORITY: sections 301.020, RSMo Supp. 2006 and 301.380, RSMo 2000. Original rule filed March 21, 1986, effective July 11, 1986. Amended: Filed Oct. 6, 2006, effective April 30, 2007.*

**Original authority 301.020, RSMo 1939, amended 1943, 1945, 1949, 1957, 1969, 1985, 1986, 1988, 1988, 1989, 1997, 2000, 2003, 2004, 2005; and 301.380, RSMo 1939, amended 1945, 1949, 1984, 1998.*

12 CSR 10-23.260 Inspection of Foreign Motor Vehicles Prior to Titling

PURPOSE: This rule sets forth the procedures for issuance of Missouri certificates of title to foreign motor vehicles not specifically manufactured for importation into this country.

Editor's Note: The secretary of state has determined that the publication of this rule in its entirety would be unduly cumbersome or expensive. The entire text of the material referenced has been filed with the secretary of state. This material may be found at the Office of the Secretary of State or at the headquarters of the agency and is available to any interested person at a cost established by state law.

(1) Some vehicles are not manufactured for importation into the United States. In order for a certificate of title to be issued, the department requires any motor vehicle imported by a registered Missouri motor vehicle dealer, or an individual, which vehicle is not manufactured for importation into the United States, to be inspected by a member of the Missouri State Highway Patrol. At the time of the inspection, the Missouri State Highway Patrol will complete a Vehicle Examination Certificate, DOR Form 551. This form indicates that the vehicle identification number has been verified and is correct.

(2) Some motor vehicles which are purchased by Missouri residents in another country and imported into the United States are manufactured for importation into the United States and conform to all legal standards. The



ownership document for these vehicles is usually a Manufacturer's Statement of Origin similar to the type issued for a motor vehicle constructed by an American manufacturer.

(A) Any application for title to a motor vehicle imported into the United States which is accompanied by a Manufacturer's Statement of Origin need not be accompanied by a DOR Form 551(B). If problems are encountered at the time the application is entered into the Department of Revenue's computer, the central office will inform the applicant to contact the Missouri State Highway Patrol to request that they inspect the vehicle and complete a Vehicle Examination Certificate.

AUTHORITY: section 301.190, RSMo 1986.
Original rule filed March 21, 1986, effective July 11, 1986.*

**Original authority: 301.190, RSMo 1939, amended 1947, 1965, 1981, 1983, 1984, 1985, 1986, 1986, 1987, 1988, 1989, 1990.*



MISSOURI DEPARTMENT OF REVENUE
MOTOR VEHICLE BUREAU
VEHICLE EXAMINATION CERTIFICATE
AND AFFIDAVIT

FORM
551
(REV. 4-89)

RETURN TO:
Missouri Department of Revenue
Motor Vehicle Bureau
P. O. Box 3325
Jefferson City, Missouri 65105-3325
Phone (314) - 751-2609

1. APPLICANT'S NAME			VALIDATION ONLY			
2. STREET ADDRESS						
3. CITY	4. STATE	5. ZIP CODE	6. TELEPHONE NUMBER ()	7. SALVAGE BUSINESS NO. (IF APPLICABLE)		

8. CHECK WHICH OF THE PARTS LISTED BELOW WERE INSTALLED ON THE MOTOR VEHICLE AND FILL IN THE REQUESTED INFORMATION FOR EACH. PHOTOCOPIES OF THE FRONT AND BACK OF THE CERTIFICATE OF TITLE OR JUNKING CERTIFICATE TO THE VEHICLE(S) FROM WHICH EACH OF THE PARTS LISTED BELOW WERE TAKEN MUST BE SUBMITTED ALONG WITH CORRESPONDING DESCRIPTIVE, NOTARIZED BILLS OF SALE. (EXCEPT MOTOR/ENGINE AND TRANSMISSION)

PARTS	YEAR	MAKE	SERIAL NUMBER	TITLE NUMBER	STATE
<input type="checkbox"/> COWL					
<input type="checkbox"/> REAR CLIP					
<input type="checkbox"/> FRAME					
<input type="checkbox"/> BODY					
<input type="checkbox"/> CAB					
<input type="checkbox"/> FRONT CLIP					
<input type="checkbox"/> FRONT-END ASSEMBLY					
<input type="checkbox"/> MOTOR/ENGINE					
<input type="checkbox"/> TRANSMISSION					

9. LIST ANY OTHER ESSENTIAL PARTS SUCH AS BUMPER, HOOD, FENDER, GRILLE, TRUNK LID, DOORS AND ATTACH CORRESPONDING BILLS OF SALE.

I DO HEREBY CERTIFY THAT THE ABOVE INFORMATION IS TRUE AND CORRECT TO THE BEST OF MY KNOWLEDGE. IF A "DR" NUMBER IS ASSIGNED, I FURTHER PLEDGE THAT THIS NUMBER SHALL BE AFFIXED TO THE MOTOR VEHICLE, AS DIRECTED BY THE DEPARTMENT OF REVENUE, WITHIN FIVE DAYS AFTER ASSIGNMENT. X

NOTARY PUBLIC EMBOSSESSER SEAL	STATE OF	COUNTY (OR CITY OF ST. LOUIS)
	SUBSCRIBED AND SWORN BEFORE ME, THIS	
	DAY OF 19	
	NOTARY PUBLIC SIGNATURE	MY COMMISSION EXPIRES
NOTARY PUBLIC NAME (TYPED OR PRINTED)		
USE RUBBER STAMP IN CLEAR AREA BELOW.		

FOR AUTHORIZED LAW ENFORCEMENT AGENCY USE ONLY - DO NOT WRITE BELOW THIS LINE

11. MAKE	12. YEAR	13. PUBLIC VIN	YEAR
14. MILEAGE	15. CYL.	15. POLICE VIN	YEAR
17. MODEL	18. ENGINE VIN		YEAR
19. COLOR	20. TRANSMISSION VIN		YEAR
21. BODY STYLE	22. EPA STICKER		YEAR

23. CHECK WHICH OF THE FOLLOWING PARTS WERE CHANGED
 COWL REAR CLIP FRAME BODY CAB FRONT CLIP FRONT-END ASSEMBLY MOTOR/ENGINE

24. THIS VEHICLE IS A NON-USA STD MOTOR VEHICLE (CHECK IF APPLICABLE)

25. REMARKS (USE ADDITIONAL SHEET OF PAPER IF NECESSARY)

26. I CERTIFY TO THE BEST OF MY KNOWLEDGE THAT MY PHYSICAL INSPECTION OF THIS VEHICLE ON _____, 19____ DISCLOSED THAT NO PERTINENT SERIAL NUMBERED PARTS OR VEHICLE IDENTIFICATION NUMBERS CAME FROM OR BELONG TO STOLEN VEHICLES. I FURTHER CERTIFY THAT THE INFORMATION IN ITEMS 11 THRU 25 IS TRUE AND ACCURATE IN FORM AND CONTENT.

27. LAW ENFORCEMENT AGENCY	28. FILE NUMBER
29. EXAMINING OFFICER'S SIGNATURE	30. EXAMINING OFFICER'S PHONE NUMBER ()
	31. BADGE NUMBER



FORM 551

PAGE 2

PLEASE REVIEW THE DEFINITIONS BELOW TO DETERMINE HOW YOUR MOTOR VEHICLE WILL BE CLASSIFIED AND TITLED.

REBUILT MOTOR VEHICLE - A motor vehicle which has been repaired or restored to its original appearance and design by means of repaired sheet metal and/or by replacement of new or major parts such as the bumper, hood, fender, grille, trunk lid, and doors of the same vehicle make, model, or description excluding major component parts (see definition of major component parts below). An original Missouri certificate of title will be issued for a rebuilt motor vehicle which conforms to this definition.

RECONSTRUCTED MOTOR VEHICLE - A vehicle that is altered from its original construction by the addition or substitution of two or more new or used major component parts, excluding motor vehicles made from all new parts, and new multistage manufactured vehicles.

MOTOR CHANGE MOTOR VEHICLE - A vehicle manufactured prior to August, 1957, which receives a new, rebuilt or used engine, and which used the number stamped on the original engine as the vehicle identification number.

SPECIALY CONSTRUCTED MOTOR VEHICLE - A motor vehicle which has not been originally constructed under a distinctive name, make, model, or type by a manufacturer of motor vehicles (EXAMPLE - DUNE BUGGY). The term "specially constructed motor vehicle" includes kit vehicles. The Missouri Certificate of Title issued will be stamped "Specially Constructed".

KIT MOTOR VEHICLE - A motor vehicle assembled by a person other than a generally recognized manufacturer of motor vehicles by the use of a "glider kit" or replica purchased from an authorized manufacturer and accompanied by a manufacturer's statement of origin. The "kit" may include the cab, drive train, etc. The Missouri Certificate of Title issued will be stamped "Specially Constructed."

NON-USA-STD MOTOR VEHICLE - A motor vehicle not originally manufactured in compliance with United States emissions or safety standards.

MAJOR COMPONENT PARTS - Include the following parts of a motor vehicle: rear clip, cowl, frame, front end assembly, front clip, body and cab.

MAJOR COMPONENT PARTS

- I. **FRONT-END ASSEMBLY** - An entire unit consisting of that portion of the body from the firewall forward, i.e., hood, both fenders, inner skirt of fenders, radiator or core support, and grille.
- II. **FRONT CLIP** - All parts of the front-end assembly plus complete cowl. It may include instrumentation and steering column. It requires cutting of vehicle floor and windshield post.
- III. **CAB** - The passenger compartment of a common truck. It is a one-piece sheet metal construction which may or may not include glass, instrumentation, steering column, and seat.
- IV. **REAR CLIP** - The complete rear sheet metal assembly formed by severing the vehicle across the floor and either through the windshield post or through the rear window post.
- V. **COWL** - The sheet metal formed by severing the vehicle across the floor in the vicinity of the front seat and severing the windshield posts. It does not include parts forward of the firewall. If a cowl is included as an integrated part of a front clip, front-end assembly, or rear clip, it will not be considered a major component part for the purpose of determining the number of such parts used in reconstructing a vehicle.
- VI. **FRAME** - The steel basic structure which runs the entire length of some vehicles and onto which the suspension parts are bolted to the lower side and the body is bolted to the top side. Unibody vehicles do not have this type of frame.
- VII. **BODY** - The shell, either of a unibody or frame-type passenger vehicle, which consists of a one-piece, integrated sheet metal construction extending from the firewall back. The body includes a cowl but not a front-end assembly. It may or may not include an interior, doors, and deck lid.

These definitions are provided for general reference only. They are subject to change. The Department of Revenue's current Administrative Rule on this subject shall control.



12 CSR 10-23.265 Statements of Non-Interest

PURPOSE: This rule sets forth the requirements to retitle when an assignment of title is erroneously completed.

(1) Whenever an assignment of title is erroneously completed or the sale of the vehicle is not consummated within sixty (60) days after the assignment of title, the seller of the vehicle must comply with one (1) of the requirements outlined as follows:

(A) If the seller of the vehicle is not a Missouri registered motor vehicle dealer, the seller of the vehicle must obtain a duplicate certificate of title from this department before the ownership of the vehicle may be transferred to another individual. The seller will be required to submit the following documents in order to obtain the duplicate title:

1. Application for Duplicate Title, DOR-108;
2. The mutilated certificate of title;
3. A statement signed by the seller and the individual (purchaser) to whom the vehicle was assigned stating the date and reason the sale was not completed;
4. A statement from any lienholder which may have been recorded in the assignment of title; and
5. Required duplicate title fee;

(B) If the seller of the vehicle is a Missouri registered motor vehicle dealer, the dealership will not be required to obtain a duplicate certificate of title in the previous owner's name but will be required to obtain an original title in the name of the dealership before the ownership of the vehicle may be transferred to another individual or dealership. The dealership will be required to submit the following documents in order to obtain the original title:

1. Application for Title, DOR-108;
2. The mutilated certificate of title;
3. A statement signed by a representative of the dealership and the individual (purchaser) to whom the vehicle was assigned stating the date and reason the sale was not completed;
4. A statement from any lienholder which may have been recorded in the assignment of title; and
5. Required title fee; and

(C) If the assignment of title by the dealership occurred on an original certificate of title issued in the name of that dealership, the dealership would be required to make an application for duplicate title as required in subsection (1)(A).

(2) If the sale of the vehicle is rescinded within sixty (60) days from the date of vehicle purchase, the purchaser/seller may apply for a refund of any taxes paid on the acquisition of the vehicle within one (1) year after the payment of taxes.

(3) This rule applies to Certificates of Title issued by Missouri as well as other states. It does not affect assignments of ownership on Manufacturers' Statements of Origin.

AUTHORITY: sections 301.190, and 301.210, RSMo Supp. 1998. Original rule filed March 21, 1986, effective July 26, 1986. Amended: Filed June 30, 1999, effective Dec. 30, 1999.*

**Original authority: 301.190, RSMo 1939, amended 1947, 1965, 1981, 1983, 1984, 1985, 1986, 1986, 1987, 1988, 1989, 1990, 1992, 1997 and 301.210, RSMo 1939, amended 1947, 1984, 1991, 1997.*

12 CSR 10-23.270 Watercraft and Outboard Motor Identification Numbers

PURPOSE: This rule sets forth the procedures for issuance of watercraft and outboard motor identification Numbers.

PUBLISHER'S NOTE: The secretary of state has determined that the publication of the entire text of the material which is incorporated by reference as a portion of this rule would be unduly cumbersome or expensive. This material as incorporated by reference in this rule shall be maintained by the agency at its headquarters and shall be made available to the public for inspection and copying at no more than the actual cost of reproduction. This note applies only to the reference material. The entire text of the rule is printed here.

(1) The Department of Revenue (department) shall require an inspection before issuing a new or replacement identification number for a watercraft or outboard motor by an officer of a law enforcement agency approved by the department. The inspection shall be completed on a Watercraft and/or Outboard Motor Affidavit of Ownership and Inspection provided by the department. The Watercraft and/or Outboard Motor Affidavit of Ownership and Inspection (revised July 2004), which has been incorporated by reference, is published by the Missouri Department of Revenue, PO Box 100, Jefferson City, MO 65105-0100. The form does not include any amendments or additions to the July 2004 revision. The form is available at all con-

tract offices and the department's central office, or may be ordered at <http://www.dort.mo.gov/mvdl/formorder/> or by mailing a written request to the Missouri Department of Revenue, PO Box 100, Jefferson City, MO 65105-0100.

(2) If the physical inspection of the watercraft discloses that the watercraft is homemade, the assigned identification number will begin with the prefix MOZ followed by a five (5) digit control number, the letter corresponding to the month of issuance, one (1) digit year the number was issued, and the two (2) digit model year of the watercraft (if unknown, the year of the inspection).

(3) If the physical inspection of the watercraft or outboard motor discloses the true and complete identification number, the assigned identification number will contain the same identification number as placed on the watercraft or outboard motor by the manufacturer.

(4) If the physical inspection of the watercraft discloses that the watercraft is manufactured and the true and complete identification number cannot be determined, the assigned identification number will begin with the prefix MOZA followed by a four (4) digit control number, the letter corresponding to the month of issuance, one (1) digit year the number was issued, and the two (2) digit model year of the watercraft (if unknown, the year of the inspection).

(5) If the physical inspection of the outboard motor discloses that the outboard motor is homemade, or manufactured and the true and complete identification number cannot be determined, the assigned identification number will begin with OB, followed by a four (4) digit number, two (2) digit year the plate was issued, and MO.

(6) After the identification number is issued, the identification number must be affixed on or within three feet (3') of the transom or stern of the watercraft or on the outboard motor below the motor cover and above the waterline.

AUTHORITY: sections 306.030 RSMo Supp. 2006 and 306.031, RSMo 2000. Emergency rule filed March 17, 1986, effective March 27, 1986, expired July 25, 1986. Original rule filed March 17, 1986, effective June 28, 1986. Amended: Filed Oct. 6, 2006, effective April 30, 2007.*

**Original authority: 306.030, RSMo 1959, amended 1969, 1975, 1985, 1995, 2006; and 306.031, RSMo 1995, amended 1997.*



12 CSR 10-23.275 Recognition of Nonresident Disabled Person Windshield Placards

PURPOSE: This rule sets forth the criteria by which Missouri will recognize and honor vehicles displaying disabled person windshield placards or disabled emblems issued to resident or nonresident operators of these vehicles by the United States government, another state, District of Columbia, or territory or possession of the United States.

(1) Missouri shall honor disabled person windshield placards or federally issued disabled emblems displayed in or on vehicles of resident or nonresident operators at all times when the vehicles are operated by residents or nonresidents within this state and specifically when the vehicles are located in parking spaces designated for the disabled. The following conditions apply:

(A) The vehicle shall be duly registered for the current year in its respective state, District of Columbia, or territory or possession of the United States;

(B) The operator of the vehicle shall comply with the provisions of section 301.143, RSMo, which allows political subdivisions of Missouri to designate parking spaces for the exclusive use of vehicles displaying a distinguishing disabled person windshield placard; and

(C) Nothing in this rule, in any way, shall be interpreted to allow a resident or nonresident operator of a vehicle displaying a disabled person windshield placard or federally issued disabled emblem to violate any state statute or lawful political subdivision's ordinances governing parking of vehicles within the boundaries of the political subdivision.

AUTHORITY: sections 301.142, RSMo Supp. 2001 and 301.271, RSMo 2000. Original rule filed April 21, 1986, effective Aug. 11, 1986. Amended: Filed Nov. 12, 1991, effective March 9, 1992. Amended: Filed Sept. 27, 2001, effective March 30, 2002.*

**Original authority: 301.142, RSMo 1977, amended 1981, 1982, 1983, 1986, 1987, 1991, 1995, 1997, 1998, 1999, 2001 and 301.271, RSMo 1958.*

12 CSR 10-23.280 Replacement of Multiyear License Plates

PURPOSE: This rule sets forth the procedures for replacement of multiyear license plates.

(1) In January 1979 the Department of Revenue began issuing multiyear license plates. The categories of multiyear license plates

are: passenger; recreational vehicle; motorcycle; motortricycle; commercial motor vehicles licensed as Local (L) 6000 and 12,000, Beyond Local (BL) 9000, BL 6000 and 12,000; shuttle bus; and van pool. These license plates were subjected to manufacturing processes which guarantee a minimum useful life of five (5) years. Holders of multiyear license plates issued at least five (5) years previously may be issued new license plates upon the payment of the annual registration (renewal) fee subject to the procedures outlined that follow:

(A) If the owner of multiyear license plates requests new plates upon renewal and surrenders the old license plates, new license plates from the office's current inventory stock may be issued upon the payment of only the appropriate renewal fee;

(B) If the owner of multiyear license plates requests new plates upon renewal, but refuses to surrender the old license plates in his/her possession, new license plates from the office's current inventory stock may be issued upon the payment of the appropriate regular registration fee and the failure to renew fee;

(C) If the owner of multiyear license plates requests new license plates upon renewal, but declares that s/he cannot surrender his/her old license plates because they were lost, stolen or destroyed, the applicant must complete an application for replacement plates and pay the appropriate replacement plate charge in addition to the regular registration fee. The applicant will be issued validation tabs from the current inventory stock and a replacement permit and receipt. The replacement plates will be manufactured with the same configuration as the original plates and will be mailed to the applicant. The applicant will affix the new validation tabs to the replacement plates when they are received by him/her;

(D) If the owner of multiyear license plates requests new plates at any time other than during the month of renewal because the license plates currently on the vehicle are at least five (5) years old, s/he may be issued replacement plates at no fee; however, the applicant must surrender the damaged license plates. The applicant will be issued replacement tabs and a replacement permit and receipt. The replacement plates will be manufactured with the same configuration as the original plates and mailed to the applicant;

(E) If the owner of multiyear license plates which are at least five (5) years old, purchases another vehicle and does not wish to transfer the license plates, the applicant may pay the appropriate transfer fee, surrender the old plates and be issued replacement

plates at no fee. The applicant will be issued replacement tabs, a replacement permit and receipt. The replacement plates will be manufactured with the same configuration as the original plates and mailed to the applicant;

(F) If the owner of multiyear license plates, which are at least five (5) years old, purchases another vehicle but does not wish to transfer the old license plates and refuses to surrender them, s/he may be issued a new set of license plates from the branch or fee agent office's current inventory stock. S/he will be required to pay the appropriate registration fee and the failure to transfer fee; and

(G) If the owner of multiyear license plates, which are at least five (5) years old, has only one (1) license plate to surrender and declares the other license plate was lost, stolen or destroyed, s/he may be issued a new set of multiyear license plates under the procedures established in subsection (1)(A) of this rule. The applicant will not be required to pay the failure to renew fee or apply for one (1) replacement plate.

(2) An owner of multiyear license plates, which are less than five (5) years old, who either refuses to renew or to transfer the plates will be issued new plates, be charged the appropriate renewal fee and be charged either a failure to renew or failure to transfer fee, whichever is applicable.

AUTHORITY: section 301.130, RSMo 1986. Original rule filed April 21, 1986, effective Aug. 11, 1986.*

**Original authority: 301.130, RSMo 1939, amended 1947, 1949, 1951, 1969, 1977, 1981, 1983, 1986.*

12 CSR 10-23.285 Titling of Motor Vehicles Sold Without Safety Inspections (Rescinded November 30, 2007)

AUTHORITY: section 307.380, RSMo Supp. 1987. Original rule filed April 21, 1986, effective Aug. 11, 1986. Rescinded: Filed May 23, 2007, effective Nov. 30, 2007.

12 CSR 10-23.290 Use of License Plates After Name Change

PURPOSE: This rule clarifies when continued use of previously issued license plates is permissible by providing examples of various name-change situations.

(1) In title transactions which involve a name change only, with no change of ownership, the owner may change the name on the certificate of title and continue to use the same



license plates assigned to the vehicle until they expire.

(2) It will be the owner's responsibility to submit proof that the name s/he is changing from and the name s/he is changing to are the same owner(s), and no change of ownership has occurred. This proof may be by certified copy of the name-change document issued by the Office of the Secretary of State or court order.

(3) If the entire ownership of a business is sold to another individual, partnership or corporation, the registration of any commercial motor vehicles owned by the business may be transferred to the new owner. A statement from the seller which gives permission for the new owners to use the license plates currently on the vehicles until their date of expiration is required. This statement is sometimes included as part of the sale contract.

(4) Examples.

(A) Corporate Name Change. ABC Corporation changes its name to DEF Corporation with no change of owners. A name-change document from the secretary of state is required. The old license plate may be used. No transfer fee will be charged unless the corporation is transferring the license from one (1) vehicle to another. If a name-change document is not presented, new license plates must be purchased.

(B) Corporate Name Change—Additional Owners. ABC Corporation owned by two (2) people changes its name to DEF Corporation which will be owned by four (4) people. A change of ownership is involved. New license plates are required. New license plates will not be required for any commercial motor vehicles involved in the change of ownership. A statement from the seller will be required.

(C) Corporate Distribution to Shareholder. ABC Corporation, owned by John Doe, wants to retitle a vehicle with the corporation's name to the individual's name. A change of ownership is involved. New license plates are required. New license plates will not be required for any commercial motor vehicles involved in the change of ownership. A statement from the seller will be required.

(D) Shareholder Contribution to Corporation. John Doe wants to retitle his privately owned vehicle to his corporation's name, ABC Corporation. A change of ownership is involved. New license plates are required. New license plates will not be required for any commercial motor vehicles involved in the change of ownership. A statement from the seller will be required.

(E) Incorporation of a Company. XYZ Company incorporates and changes to XYZ Corporation. A change of ownership is involved. New license plates are required. New license plates will not be required for any commercial motor vehicles involved in the change of ownership. A statement from the seller will be required.

(F) Company Name Change. XYZ Company changes its name to ABC Company with no change of ownership. A name-change document from the secretary of state is required. The old license plates may be used. No transfer fee is charged unless the company or corporation is transferring the license from one (1) vehicle to another. If a name-change document cannot be presented, new license plates must be purchased.

(G) Individual to Company Name Change. John Doe wants to retitle his privately owned vehicle to his privately owned company, John's Delivery Company. A copy of Registration of Fictitious Name form filed with the secretary of state is required. The old license plates may be used. No transfer fee is charged unless John Doe is transferring the license plates from one (1) vehicle to another. If the Registration of Fictitious Name form cannot be presented, new license plates must be purchased.

(H) Company Name Change—Additional Owners. ABC Company owned by two (2) people changes its name to XYZ Company owned by four (4) people. A change of ownership is involved. New license plates are required. New license plates will not be required for any commercial motor vehicles involved in the change of ownership. A statement from the seller will be required.

(I) Individual Name Change. Because of marriage, divorce or establishment of name by common usage, Mary Jones changes her last name on a certificate of title to Mary Johnson. Mary must present her Missouri driver's license showing her name. This will constitute sufficient proof of name change. If Mary does not have a Missouri driver's license, or has not applied for a new driver's license which reflects her name change, she must complete an affidavit stating her name change was due to marriage or divorce, or present three (3) affidavits stating the name change was due to establishment of name by common usage. Her old license plates may be used if Mary's previous name was on the original title.

(J) Court Authorized Individual Name Change. John Brown wants to change his name to Bobby Smith on a certificate of title. A certified copy of the court order authorizing the name change is required. His old license plates may be used.

AUTHORITY: sections 301.140, RSMo Supp. 1987 and 301.442, RSMo 1986. Original rule filed April 21, 1986, effective Aug. 11, 1986.*

**Original authority: 301.140, RSMo 1987, amended 1947, 1951, 1978, 1979, 1986, 1987 and 301.442, RSMo 1981.*

12 CSR 10-23.295 Witnessing Proof of Federal Heavy Vehicle Use Tax Payment or Exemption

PURPOSE: Section 301.025, RSMo prohibits the director of revenue from registering any vehicle subject to Federal Heavy Vehicle Use Tax unless the applicant submits proof of payment or exemption. This rule clarifies what constitutes proof of payment or exemption of the Federal Heavy Vehicle Use Tax imposed by Section 4481 of the Internal Revenue Code.

(1) All applications (new or renewal) for a commercial motor vehicle registration with a licensed gross weight of sixty thousand ten pounds (60,010 lbs.) or above must be accompanied by proof that federal heavy vehicle use tax has been paid on the vehicle or that the vehicle is tax exempt. Acceptable proof includes:

(A) Schedule 1 to the federal Heavy Highway Vehicle Use Tax Return, Form 2290 appropriately stamped paid or received by the Internal Revenue Service; or

(B) A copy of the front and back of the applicant's cancelled check made payable to the Internal Revenue Service for the heavy vehicle use tax and the applicant's copy of Schedule 1 to Form 2290.

(2) Proof of tax payment or tax exemption is not required for—

(A) Federal, state, city, and county owned vehicles;

(B) Vehicles owned by the American National Red Cross, a nonprofit volunteer fire department, ambulance association, or rescue squad; or

(C) Vehicles purchased no more than sixty (60) days prior to the date of application for registration.

(3) The Heavy Highway Vehicle Use Tax Return (FORM 2290) and the Schedule 1 to FORM 2290, may be obtained at www.irs.gov, or by phone at 1 (800) 829-3676, or at many Internal Revenue Service offices, post offices, and libraries.

AUTHORITY: section 301.025, RSMo Supp. 2006. Original rule filed May 27, 1986,*



effective Aug. 25, 1986. Amended: Filed June 1, 2007, effective Nov. 30, 2007.

**Original authority: 301.025.2, RSMo 1951, amended 1974, 1984, 1987, 1995, 1997, 1998, 1999, 2000, 2004, 2005.*

12 CSR 10-23.300 Use of Local Commercial Motor Vehicle License Plates for Farm or for Farming Transportation Operations

PURPOSE: This rule sets forth the manner of the use of local commercial motor vehicle license plates issued to motor vehicles used for farm or farming transportation operations.

(1) Any applicant who requests a farm license plate will be issued a local commercial license plate for the appropriate gross weight category and an “F” tab. The tab (which shall be a black letter F on a yellow background) referred to as a “farm” tab, should be affixed to the license plate in the lower left-hand corner. If the owner is issued Local 6,000 or Local 12,000 license plates, two (2) farm tabs must be issued. If the owner is issued a Local 18,000 through 80,000 license plate, one (1) farm tab will be issued. The farm tab(s) shall be issued at no fee.

(2) A farmer operating his/her truck on a local commercial motor vehicle license plate with a farm tab may travel beyond the fifty (50) mile limit as defined in section 301.010(25), RSMo while empty or loaded. If the motor vehicle is loaded, the property being transported must be going to or from the farm for use in the operation of the farm.

(3) A farmer operating on a local commercial motor vehicle license plate with a farm tab may not make a for hire haul.

AUTHORITY: section 301.030, RSMo 2000. Original rule filed June 9, 1986, effective Sept. 26, 1986. Amended: Filed June 24, 2003, effective Dec. 30, 2003.*

**Original authority: 301.030, RSMo 1947, amended 1951, 1965, 1974, 1983, 1986, 1993, 1995, 1997.*

12 CSR 10-23.305 No-Fee Transactions

PURPOSE: This rule establishes when the department may issue, on a no-fee basis, any replacement certificate of title, license plate or tab.

(1) When the department’s records indicate a certificate of title, license plate or tab was

mailed to any applicant and the applicant contacts the department stating s/he did not receive the item in the mail, the department will issue a duplicate certificate of title, license plate or tab at no fee provided the applicant submits an application and a notarized affidavit to the department. This rule will apply if a certificate of title, license plate or tab was not received by the applicant within one (1) calendar year after the item was issued (mailed) by the department. After the one (1) calendar year period has elapsed, the applicant must submit the required documents and fee to obtain the duplicate title, replacement plates, tabs or plates and tabs.

(2) The application must be completed in its entirety. The affidavit must state that the certificate of title, license plate or tab was not received by the applicant and, if the item is received at a later date, it will be returned to the department immediately.

AUTHORITY: section 136.030, RSMo 1986. Original rule filed June 10, 1986, effective Sept. 26, 1986.*

**Original authority: 136.030, RSMo 1945, amended 1947, 1949, 1965.*

12 CSR 10-23.310 Issuance of Special Fuel Decals

PURPOSE: This rule establishes the procedures for issuance of special fuel decals.

(1) The owners of the motor vehicles powered by liquefied petroleum (LP) gas, natural gas or electricity annually shall purchase a special fuel decal prior to January 31 and pay the annual decal fee set by law. For motor vehicles obtained and converted to run on LP gas, natural gas or electricity after January 31 of any year, the decal fee shall be reduced by one-twelfth (1/12) for each month which has elapsed since the beginning of the year. The owner of any vehicle that was titled, registered and equipped to run on LP gas, natural gas or electricity as of January 31 shall pay the full year’s fee.

(A) Example A: An applicant has May plates on a vehicle equipped to run on LP gas and applies for a special fuel decal during February of the following year. The full fee is due.

(B) Example B: An applicant purchases a vehicle equipped to run on LP gas in May and titles and registers his/her vehicle in the same month. The applicant will be issued a special fuel decal and the fee would be prorated over eight (8) months.

(C) Example C: An applicant owns a vehicle which has been previously titled and registered and converts it to use LP gas in May. The applicant will be issued a special fuel decal and the fee would be prorated over eight (8) months.

(2) The special fuel decal fee paid for each motor vehicle is transferable upon either a change of ownership of the motor vehicle or if the LP gas, natural gas or electrical equipment is removed from the vehicle by the seller upon change of ownership and is subsequently installed in another vehicle acquired or owned by the seller.

(A) When the ownership of a motor vehicle is transferred to another person, the decal issued to the motor vehicle will remain with the vehicle and shall be transferred to the new owner. The new owner shall complete a new application for the special fuel decal but no fee will be charged for the decal transfer.

(B) When LP gas equipment, natural gas equipment or electrical power equipment is removed by the owner upon sale of the vehicle and later installed on another vehicle owned or purchased by the same individual, the special fuel decal may be transferred to the newly equipped vehicle. In order to receive credit, the owner will be required to remove the special fuel decal from the vehicle from which s/he removed the LP gas, natural gas or electrical power equipment and surrender the decal. The department’s fee agent and branch office employees will verify the removal of the decal and issue a replacement decal for the balance of the registration period at no fee.

(3) If a special fuel decal is lost, stolen, mutilated or destroyed, the owner shall make application for a replacement decal and pay the replacement fee established by law.

(4) If an owner of a commercial motor vehicle powered by LP gas, natural gas or electricity wishes to change the licensed gross weight/zone of the commercial motor vehicle and that change puts the vehicle into an increased special fuel decal fee category, additional decal fees shall be collected. If the change of weight/zone would require a decrease in the decal fee from what was originally paid, no credit shall be allowed.

AUTHORITY: section 142.611, RSMo 1986. Original rule filed June 9, 1986, effective Sept. 26, 1986. Amended: Filed Sept. 16, 1991, effective Jan. 13, 1992.*

**Original authority: 142.611, RSMo 1972.*



12 CSR 10-23.315 Motorized Bicycles

PURPOSE: This rule clarifies titling, registration, use and regulation of motorized bicycles.

(1) Section 301.010(18), RSMo defines a motorized bicycle as any two (2)-wheeled or three (3)-wheeled device having an automatic transmission and a motor with a cylinder capacity of not more than fifty (50) cubic centimeters, which produces less than three (3) gross brake horsepower and is capable of propelling the device at a maximum speed of not more than thirty (30) miles per hour on level ground.

(A) Because a motorized bicycle (moped) is neither a vehicle nor a motor vehicle, the Department of Revenue does not title or license these units.

(B) Motorized bicycles are not required to be licensed to be operated on the streets and highways. The registration requirements of Chapter 301, RSMo pertain only to motor vehicles, trailers and all-terrain vehicles.

(C) Motorized bicycles may not be operated upon any interstate highway. They may be operated upon any other public street or highway.

(D) The operator of a motorized bicycle does not have to be motorcycle qualified to operate this unit.

(E) The motorcycle helmet law does not apply to motorized bicycles.

(F) Those persons engaged in the business of selling motorized bicycles do not have to be registered dealers.

(G) An operator of a motorized bicycle is subject to point assessment for moving violations.

(H) An operator of a motorized bicycle shall have a valid driver's license.

AUTHORITY: sections 301.010, 301.020, 302.020, 307.195, RSMo Supp. 1989, 301.190, RSMo Supp. 1990 and 307.190 and 307.193, RSMo 1986.* Original rule filed June 10, 1986, effective Sept. 26, 1986. Amended: Filed Oct. 30, 1989, effective Feb. 25, 1990.

*Original authority: 301.010, RSMo 1939, amended 1945, 1949, 1951, 1969, 1974, 1979, 1980, 1983, 1985, 1986, 1987, 1988, 1989; 301.020, RSMo 1939, amended 1943, 1945, 1949, 1957, 1969, 1985, 1986, 1986, 1987, 1988, 1989, 1990; 302.020, RSMo 1939, amended 1951, 1967, 1984, 1988, 1989; 307.190 and 307.193, RSMo 1977, amended 1980; 307.195, RSMo 1980, amended 1989.

12 CSR 10-23.320 Assessment of Motor Vehicle and Trailer License Plate Transfer Fee

PURPOSE: This rule clarifies when a license plate transfer fee shall be assessed.

(1) When ownership of a registered motor vehicle or trailer is transferred, the original owner may register another motor vehicle or trailer under the same license plate number provided the owner pays the transfer fee set by law and also that the motor vehicle or trailer being newly registered is of either a horsepower, gross weight or (in the case of a passenger-carrying commercial motor vehicle) a seating capacity not in excess of the originally registered vehicle. When the newly registered vehicle is of greater horsepower, gross weight or seating capacity than the previously owned and registered vehicle, the owner shall pay the transfer fee set by law and a pro rata portion for the difference in registration fees. Occasions when the license plate transfer fee shall not be assessed are detailed as follows:

(A) When ownership of a registered motor vehicle or trailer is transferred during or immediately prior to the month of expiration of the owner's license plates, or license plates are transferred to a previously nonused vehicle, the original owner may register another motor vehicle or trailer under the same license plate number without paying a license plate transfer fee if the motor vehicle or trailer being registered is of either a horsepower, gross weight or (in the case of a passenger-carrying commercial motor vehicle) a seating capacity not in excess of the originally owned and registered vehicle. For example, an individual purchases a new vehicle—

1. During the month of expiration of his/her license plates and wants to transfer and renew his/her license plates at the time s/he titles the new vehicle. No license plate transfer fee shall be charged to the applicant but the applicant shall be charged the full year's registration fee for the new vehicle;

2. Immediately prior to the month of expiration of his/her license plates. The applicant submits an application for title to his/her new vehicle during the month his/her license plates expire and submits an affidavit of nonuse indicating the vehicle has not been operated on the streets and highways since the date of purchase. No license plate transfer fee shall be charged to the applicant, but the applicant shall be charged the full year's registration fee for the new vehicle; and

3. After the sixteenth day of the month immediately prior to the month of expiration of his/her license plates. The applicant

desires to transfer and renew his/her license plates early on the new vehicle when s/he makes application for title. No transfer fee shall be charged to the applicant but the applicant shall be charged the full year's registration fee for the new vehicle.

AUTHORITY: section 301.140, RSMo Supp. 1987.* Original rule filed July 25, 1986, effective Nov. 28, 1986.

*Original authority: 301.140, RSMo 1939, amended 1947, 1951, 1978, 1979, 1986, 1987.

12 CSR 10-23.325 Transfer of Passenger Vehicle License Plates From One Horsepower Category to Another—Waiver of Additional Registration Fees and Lack of Refund Provision

PURPOSE: This rule clarifies the procedures by which payment of additional registration fees may be waived upon transfer of passenger vehicle license plates, as well as the director's lack of authority to refund previously paid registration fees in certain license plate transfer situations.

(1) Should an applicant desire to transfer current passenger vehicle license plates from a vehicle of a lesser horsepower to a vehicle of a greater corresponding horsepower, s/he may do so without payment of an additional registration fee provided the applicant submits a validated registration certificate as proof that s/he originally purchased the license plates to be transferred within the same registration year and for the greater registration category to which s/he wishes to return.

(2) Should an applicant desire to transfer current passenger vehicle license plates from a vehicle of a greater horsepower to a vehicle of a lesser corresponding horsepower, s/he shall not be entitled to a refund of the difference in registration fees between the greater and lesser categories.

AUTHORITY: section 301.140, RSMo Supp. 1987.* Original rule filed July 25, 1986, effective Nov. 28, 1986.

*Original authority: 301.140, RSMo 1939, amended 1947, 1951, 1978, 1979, 1986, 1997.

12 CSR 10-23.330 Registration of Motorcycles or Motortricycles

PURPOSE: This rule clarifies the procedures for issuance of motorcycle or motortricycle license plates.



(1) The department shall issue one (1) license plate to a motorcycle or motortricycle.

(2) The motorcycle or motortricycle license plate shall be renewable by the issuance of a tab. Motorcycle or motortricycle license plates expire on April 30 of the registration period.

(3) The registration fee for a motorcycle or motortricycle purchased or acquired in any given month, and for which the owner does not hold a motorcycle or motortricycle license plate to transfer, shall be prorated based upon the number of months from the date of operation until April of the expiration of the registration year.

AUTHORITY: sections 301.055 and 301.080, RSMo 2000. Original rule filed July 25, 1986, effective Nov. 28, 1986. Amended: Filed June 24, 2003, effective Dec. 30, 2003.*

**Original authority: 301.055, RSMo 1969, amended 1984; 301.080, RSMo 1947, amended 1951, 1969, 1987.*

12 CSR 10-23.335 Issuance of Title to a Surviving Spouse or Unmarried Minor Children of a Decedent

PURPOSE: This rule clarifies the issuance of an original certificate of ownership to one automobile or other passenger motor vehicle to a surviving spouse, if any, or to surviving unmarried minor children in equal shares.

(1) When a decedent has not disposed of an automobile or other passenger motor vehicle by will, the surviving spouse, or in the event there is no surviving spouse, the unmarried minor children may equally take title to one (1) automobile or other passenger motor vehicle including a pickup truck without the issuance of a probate court order. The surviving spouse or unmarried minor children shall submit the following documents to the Department of Revenue in order to obtain a certificate of title:

(A) Application for Title;

(B) Affidavit to Establish Title to Exempt Property;

(C) Certificate of title in the decedent's name or with the decedent named as purchaser of the motor vehicle;

(D) Copy of the death certificate;

(E) Proof that the applicant was legally married to the decedent or is an unmarried minor child of the decedent, if applicable; and

(F) All taxes and fees required by law.

(2) For the purposes of obtaining a certificate of ownership, one (1) automobile or other passenger motor vehicle, as provided in section 474.250, RSMo, shall include any motor vehicle which is titled in the name of the decedent or assigned to the decedent. The ownership of non-passenger vehicles such as recreational vehicles, all-terrain vehicles, trailers, commercial trucks (trucks licensed for over eighteen thousand (18,000) pounds), buses and boats and outboard motors shall not be transferred by the Department of Revenue to a surviving spouse or unmarried minor children without presenting an appropriate court order.

AUTHORITY: section 474.250, RSMo 2000. Original rule filed July 25, 1986, effective Nov. 28, 1986. Amended: Filed July 17, 1989, effective Oct. 27, 1989. Amended: Filed Sept. 16, 2004, effective March 30, 2005.*

**Original authority: 474.250, RSMo 1939, amended 1955, 1957, 1980, 1996.*

12 CSR 10-23.340 Imposition and Waiver of Motor Vehicle and Trailer Titling and Registration Penalties

PURPOSE: This rule clarifies the reasons for imposition and waiver of all penalties assessed by the department on motor vehicles and trailers.

(1) The department shall assess penalties on three (3) types of motor vehicle and trailer titling and registration transactions. These penalties are—a delinquent registration renewal penalty, a failure to title penalty and a failure to renew or transfer a multiyear license plate penalty. All penalties may be waived by the department under certain circumstances.

(A) Delinquent Registration Renewal Penalty. If an owner of a multiyear license plate submits his/her application for renewal on the first day of the month following the month of expiration of the license plate, a delinquent registration renewal penalty shall be assessed. If the last day of the month of expiration falls on a Saturday, Sunday or legal state holiday, the following state working day is penalty free. If, for example, an owner has November license plates and the last day of November falls on Sunday, Monday, December 1 would be considered penalty free for all November renewals.

1. Once a motor vehicle is registered for use on Missouri highways, it is subject to annual registration. The motor vehicle is to be registered annually whether or not it is

actually on or off the highways for any period of time. This obligation to register the vehicle annually continues until the owner ceases to operate the vehicle on Missouri highways, at which time s/he is required to return his/her license plates to the director of revenue within ninety (90) days. If an owner of a motor vehicle surrenders his/her license plates to an office of the Department of Revenue within the ninety (90)-day period after ceasing to operate the motor vehicle, s/he may register that same vehicle again at a later date (see subparagraphs (1)(A)1.A.–C.) without being subject to a delinquent registration renewal penalty.

A. If an owner elects to renew the registration of a vehicle which s/he has ceased operating anytime during the twelve (12)-month period following the expiration of the license plates, s/he will be issued the appropriate license plate and validation tabs and be charged the appropriate twelve (12)-month registration fee. A delinquent registration renewal penalty shall not be charged provided the owner submits the receipt documenting his/her surrender of previously issued license plates.

B. An owner's registration shall be automatically cancelled after one (1) year from the date of expiration of a Missouri license plate. If an owner elects to cease operation of his/her vehicle, and the license plates on the vehicle have been expired for at least one (1) year, the owner will not be required to pay a delinquent registration renewal penalty if s/he elects to relicense the vehicle after one (1) year from the date of expiration of the license plates.

C. The owner of a motor vehicle may not surrender his/her license plates and request new license plates on the same day in order to avoid paying a delinquent registration renewal penalty.

(B) Failure to Title Penalty. If a purchaser of a motor vehicle or trailer fails to make application for a certificate of ownership within thirty (30) days after acquiring a motor vehicle or trailer, the department shall assess the title penalty set by law for each thirty (30)-day period of delinquency, not to exceed the maximum penalty allowed. The first penalty fee shall be assessed on the 31st day of delinquency. If the 30th, 60th, 90th, 120th, 150th, 180th, 210th, 240th or the 270th day of delinquency falls on a Saturday, Sunday or legal state holiday, the penalty fee shall not be imposed on the next state working day. If, for example, an individual purchases a motor vehicle on August 1, and the 30th day of the first period of delinquency falls on Sunday, August 31, the first penalty



would not be imposed on Monday, September 1 but on Tuesday, September 2.

(C) Penalty for Failure to Renew or Transfer a Multiyear License Plate. A penalty fee shall be imposed on any applicant who elects not to renew or transfer a multiyear license plate. Multiyear license plates are issued to—passenger vehicles; recreational vehicles; motorcycles; motortricycles; commercial motor vehicles registered for Local (L) 6000, L 12,000, Beyond Local (BL) 6000, BL 9000 and BL 12,000; shuttle buses; and van pool vehicles. If an applicant does not renew the multiyear license plates currently registered to his/her vehicle, but requests that new multiyear license plates be issued, a penalty fee shall not be imposed provided the applicant changes license plate categories. For example, if the applicant has regular passenger license plates and requests disabled person license plates, no failure to renew or transfer penalty shall be imposed.

AUTHORITY: sections 301.050, RSMo 1986 301.190 and 301.300, RSMo Supp. 1990. Original rule filed July 30, 1986, effective Nov. 28, 1986.*

**Original authority: 301.050, RSMo 1947, amended 1953, 1984; 301.190, RSMo 1939, amended 1947, 1965, 1981, 1983, 1984, 1985, 1986, 1987, 1988, 1989, 1990; and 301.300, RSMo 1939, amended 1941, 1947, 1981, 1984, 1988, 1990.*

12 CSR 10-23.345 Definition of Major Component Parts of a Motor Vehicle

PURPOSE: This rule clarifies, by written definitions and illustrations, the seven major component parts commonly used in the reconstruction of a motor vehicle.

(1) The seven (7) major component parts which are commonly used to reconstruct a motor vehicle shall be defined solely for reconstruction purposes as follows. The written definition of each major component part is further clarified by an artist's drawing:

(A) Front-end assembly—An integrated unit consisting of that portion of the body from the firewall forward, that is, hood, both fenders, inner skirt of fenders, radiator or core support and grille;

(B) Front clip—All parts of the front-end assembly plus complete cowl. It may include instrumentation and steering column. It requires cutting of vehicle floor and windshield post;

(C) Cab—The passenger compartment of a common truck. It is a one (1)-piece sheet metal construction which may or may not include glass, instrumentation, steering column and seat;

(D) Rear clip—The complete rear sheet metal assembly formed by severing the vehicle across the floor and either through the windshield post or through the rear window post;

(E) Cowl—The sheet metal formed by severing the vehicle across the floor in the vicinity of the front seat and severing the windshield posts. It does not include parts forward of the firewall. If a cowl is included as an integrated part of a front clip, front-end assembly or rear clip, it shall not be considered a major component part for the purpose of determining the total number of the major component parts used in the reconstruction of a motor vehicle;

(F) Frame—The steel basic structure which runs the entire length of some vehicles and onto which the suspension parts are bolted to the lower side and the body is bolted to the top side. Unibody vehicles do not have this type of frame; and

(G) Body—The shell, either of a unibody or frame-type passenger vehicle, which consists of a one (1)-piece, integrated sheet metal construction extending from the firewall back. The body includes a cowl but not a front-end assembly. It may or may not include an interior, doors and deck lid. It does not include a frame as defined in subsection (1)(F).

AUTHORITY: section 301.010, RSMo Supp. 1989. Original rule filed Sept. 1, 1986, effective Nov. 28, 1986.*

**Original authority: 301.010, RSMo 1939, amended 1945, 1949, 1951, 1969, 1974, 1979, 1980, 1983, 1983, 1985, 1986, 1986, 1987, 1988, 1989.*



FRONT END ASSEMBLY

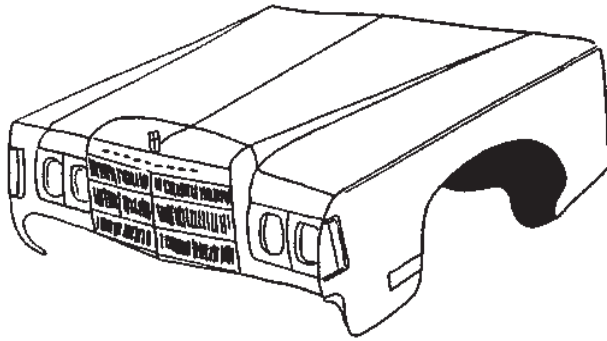

REAR CLIP

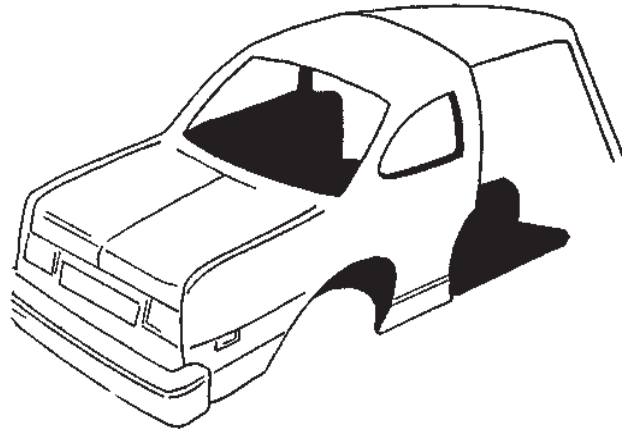

FRONT CLIP

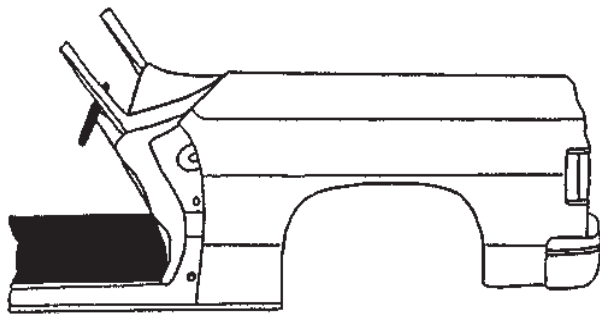

COWL

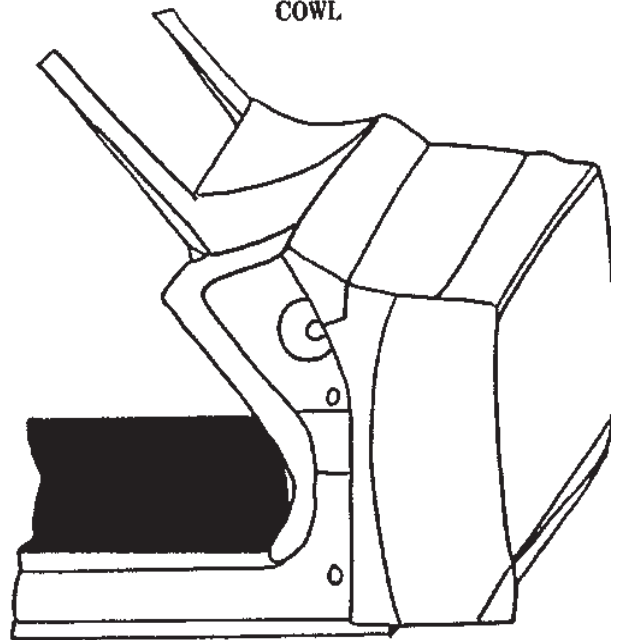

TRUCK CAB

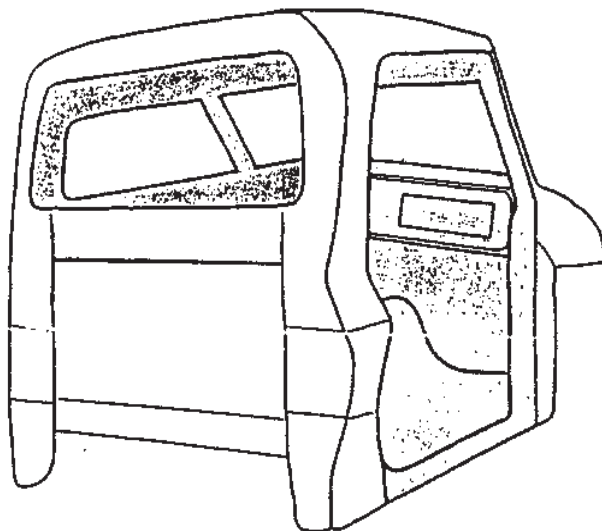

FRAME

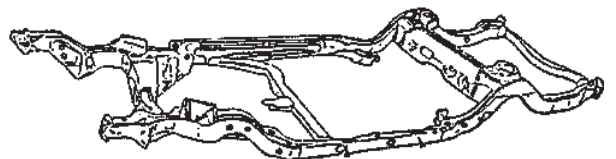

**12 CSR 10-23.350 Honorary Consular License Plates**

PURPOSE: This rule establishes procedures for the issuance of license plates to honorary consuls.

Editor's Note: The secretary of state has determined that the publication of this rule in its entirety would be unduly cumbersome or expensive. The entire text of the material referenced has been filed with the secretary of state. This material may be found at the Office of the Secretary of State or at the headquarters of the agency and is available to any interested person at a cost established by state law.

- (1) Under the authority of the Foreign Missions Act, 22 U.S.C. Section 4301, the Office of Foreign Missions of the United States Department of State has begun issuing a new series of motor vehicle license plates for vehicles owned by foreign missions and their authorized representatives. These new federal license plates replace and supersede the special diplomatic and consular plates formerly issued by the various states including Missouri. The new law also provides for federal titling of vehicles owned by foreign missions and their authorized representatives.
- (2) The new federal license plates are issued to the following categories of personnel:
 - (A) Representatives of foreign missions (nationwide) having diplomatic status;
 - (B) Representatives of foreign missions (nationwide) having consular status;
 - (C) Representatives of foreign missions (nationwide) having official status;
 - (D) Official representatives of foreign missions (United Nations) whose member states maintain permanent missions at the United Nations headquarters;
 - (E) Official representatives of foreign missions (United Nations) assigned to the United Nations and family members;
 - (F) Officials of the Secretariat of the United Nations; and
 - (G) Official representatives to the Organization of American States.
- (3) The new federal license plates are easily recognizable, being painted red, white and blue, are the standard six inches by twelve inches (6" × 12") in size and bear the words Issued by the United States Department of State at the bottom.
- (4) In accordance with the Foreign Missions Act, 22 U.S.C. Section 4301, the United States Department of State has directed that license plates issued by any state, including Missouri, to honorary consuls must contain words, symbols and colors that are clearly distinguishable from the federal plates. Furthermore, each state has been requested to refrain from embossing the words, CONSULAR OFFICER on the license plates issued by the states. This procedure should assist law enforcement agencies in determining if the license plate displayed on a motor vehicle is a federal- or state-issued plate. Missouri may not issue license plates to any motor vehicle which is required to be registered with the federal government.
- (5) Honorary consuls are defined as United States nationals or permanent residents who are appointed as honorary consular officers of foreign missions. The United States Department of State has notified Missouri that honorary consuls will not be permitted to register their vehicles under the federal program. However, honorary consuls are authorized under section 26.140, RSMo to use Missouri motor vehicle license plates which identify them as honorary consular officers. Accordingly, the director of revenue has established a category of specialized personalized license plates for issuance to honorary consuls patterned after the provisions of section 301.144.2., RSMo.
- (6) Honorary consular license plates shall consist of white letters and numerals on a royal blue field. The configuration of these plates shall consist of the letter C followed by a dash and the numerals one through and including sixty-six (1-66). At the bottom of the royal blue field shall appear the words HON. CONSUL in the place of Show Me State.
- (7) No more than one (1) set of two (2) honorary consular license plates shall be issued to a qualified applicant.
- (8) A qualified applicant is an honorary consular officer who—
 - (A) Appears on the United States Department of State, Office of Foreign Missions, Foreign Consular Duty Officer List;
 - (B) Has registered as an honorary consular officer with the United States Department of State and has been duly issued an exequatur or a diplomatic note by that department which remains valid;
 - (C) Has presented his/her credentials to the governor of Missouri;
 - (D) Has obtained from the Missouri secretary of state an identification card identifying him/her as an honorary consular officer; and
 - (E) Is a resident of Missouri.
- (9) Honorary consular license plates shall only be issued to passenger motor vehicles subject to the registration fees provided in section 301.055, RSMo.
- (10) Applicants for honorary consular license plates shall be required to comply with all Missouri laws and rules relating to the taxing, titling, registration and safety inspection of motor vehicles.
- (11) Any person desiring to obtain a set of two (2) honorary consular license plates must make application and shall pay an annual personalized plate fee of fifteen dollars (\$15) in addition to the regular registration fees for passenger vehicles as detailed in section 301.055, RSMo. Initial application for honorary consular license plates shall be submitted to the Department of Revenue, Motor Vehicle Bureau, P.O. Box 100, Jefferson City, MO 65105 and shall be accompanied by the personalized plate fee, a paid personal property tax receipt of the previous calendar year or a statement of nonassessment for the same period, a vehicle safety/emissions inspection not more than sixty (60) days old, a statement certifying proof of insurance and a copy of the honorary consular officer identification card issued by the Missouri secretary of state. Upon approval, honorary consular license plates will be issued by the Motor Vehicle Bureau. Subsequent annual renewals may be accomplished at any branch or fee agent office statewide where the renewing applicant will be issued universal registration renewal tabs.
- (12) Prior to the receipt of honorary consular license plates, the applicant must surrender all previously issued license plates which bear the words Consular Officer and pay any additional fees due. If no consular officer plates were issued, the applicant must surrender the regular license plates which the honorary consular license plates will replace. If the honorary consular license plates are to be issued for a period of less than one (1) full year, the department shall assess registration fees on a prorated basis. No refunds shall be made for any unused portion of registration fees for any license plates surrendered in exchange for honorary consular license plates.
- (13) Applications for renewal of honorary consular license plates shall be filed with the Department of Revenue prior to the last regular work day of January each year. All plates annually expire on January 31.
- (14) According to the United States Department of State, honorary consular officers who



have been issued license plates identifying them as honorary consuls are not entitled to diplomatic immunity from any state, county or municipal parking or traffic laws or from arrest or detention for violation of those laws.

(15) According to the United States Department of State, honorary consuls are not exempt from any taxes whatsoever, including county or City of St. Louis personal property tax, state sales or use taxes, or local sales taxes. No tax exemption shall be granted in connection with any application for honorary consular license plates unless exempt status is certified to the department by the United States Department of State for each proposed transaction.

(16) On January 1, 1987, all consular officer license plates previously issued by the Missouri Department of Revenue which bear the words Consular Officer and which have white lettering on a red field shall become invalid.

AUTHORITY: sections 26.140 and 301.135, RSMo 1986 and 301.144, RSMo Supp. 1989. Original rule filed Oct. 3, 1986, effective Dec. 26, 1986. Emergency amendment filed Oct. 30, 1989, effective Nov. 9, 1989, expired March 8, 1990. Amended: Filed Oct. 30, 1989, effective Feb. 25, 1990.*

**Original authority: 26.140, RSMo 1955, amended 1985; 301.135, RSMo 1981; and 301.144, RSMo 1977, amended 1979, 1983, 1984, 1989.*

12 CSR 10-23.355 Junking Certificates for Motor Vehicles

PURPOSE: This rule establishes the procedures for issuance of a junking certificate.

Editor's Note: The form mentioned in this rule follows 12 CSR 10-23.265.

(1) The department will issue a junking certificate to the purchaser of a vehicle which is sold for parts, scrapping or junking and not for rebuilding or reconstruction. An applicant must submit the following documents to the department in order to obtain a junking certificate:

(A) Application for junking certificate; and

(B) Proof of ownership in the form of a properly assigned salvage certificate of title, junking certificate, original certificate of title, court order or proof of compliance with state statutes.

(2) If the seller of the vehicle has not made application for a salvage certificate of title, junking certificate or an original certificate of

title in his/her name but the seller has been, nonetheless, properly assigned that certificate by the previous owner, the seller must provide the purchaser with a notarized, descriptive bill of sale to the vehicle as well as the outstanding certificate of ownership on which the seller appears as the last assignee.

(3) If the department determines the seller violated the provisions of section 301.190, RSMo by failing to take title to and pay taxes on the vehicle, the department will initiate tax assessment action against the seller. The action shall in no way impede issuance of a junking certificate to the purchaser of the vehicle; except that, if the department's records show that a lien has been perfected on the vehicle, the applicant for a junking certificate must obtain and submit a notarized lien release from the prior owner's lienholder before a junking certificate may be issued.

AUTHORITY: section 301.227, RSMo Supp. 1990. Original rule filed Nov. 18, 1986, effective March 12, 1987.*

**Original authority: 301.227, RSMo 1979, amended 1983, 1984, 1986, 1988, 1990.*

12 CSR 10-23.365 Issuance of Nonresident Salvage-Buyer's Identification Card (Rescinded February 29, 2008)

AUTHORITY: section 301.218, RSMo 1986. Original rule filed Nov. 18, 1986, effective March 12, 1987. Emergency rescission filed Aug. 8, 2007, effective Aug. 28, 2007, expired Feb. 23, 2008. Rescinded: Filed Aug. 8, 2007, effective Feb. 29, 2008.

12 CSR 10-23.370 Issuance of Certificates of Title to Recreational Vehicles Manufactured by Two Separate Manufacturers

PURPOSE: This rule establishes uniform procedures to be followed in the titling of multistage, manufactured recreational vehicles or motor homes often referred to as multistage vehicles.

(1) When recreational vehicles or motor homes are manufactured by separate manufacturers and have separate and distinct Manufacturers' Statements of Origin (MSO) issued for the unit, the following titling procedures shall apply:

(A) When an application for a Missouri certificate of title to a new recreational vehicle or motor home is submitted, both the MSO issued by the vehicle's chassis or first-

stage manufacturer and the MSO issued by the vehicle's final-stage manufacturer must accompany the application;

(B) The year model assigned to the recreational vehicle shall be obtained from the MSO issued by the recreational vehicle's final-stage manufacturer;

(C) The vehicle make assigned to a vehicle shall be obtained from the MSO issued by the vehicle's final-stage manufacturer. For example, first-stage manufacturer, Chrysler Corporation builds a Dodge chassis which is subsequently made into a recreational vehicle or motor home by the final-stage manufacturer, Winnebago. The make of the vehicle will be Winnebago. Note, however, that the make of a Ford van converted by a custom converter to a recreational vehicle which does not meet the requirements of a motor home detailed in section (2) must remain a Ford; and

(D) The vehicle identification number (VIN) assigned to the recreational vehicle or motor home shall be the chassis identification number shown on the first-stage MSO. For example, the VIN for a completed Winnebago recreational vehicle or motor home manufactured on a Dodge chassis will be the identification number assigned by Chrysler Corporation to the Dodge chassis.

(2) For the purpose of this rule, motor home shall be defined as a new vehicular unit, designed to provide temporary living quarters, built into as an integral part of, or permanently attached to a self-propelled motor vehicle chassis or van. The vehicle must contain permanently installed independent life support systems which meet the American National Standards Institute/National Fire Protection Association (ANSI/NFPA) 501C Standard and provide at least four (4) of the following facilities: cooking, refrigeration or ice box, self-contained toilet, heating or air conditioning, or both, a portable water supply system including a faucet and sink, separate one hundred ten to one hundred twenty-five (110-125)-volt electrical power supply or a liquefied petroleum (LP) gas supply or both. The basic types are specified as follows:

(A) Type A. A raw chassis upon which is built a driver's compartment and an entire body which provides temporary living quarters as previously defined;

(B) Type B. A completed van-type vehicle which has been altered to provide temporary living quarters as defined previously; and

(C) Type C. An incomplete vehicle upon which is permanently attached a body designed to provide temporary living quarters as previously defined.



AUTHORITY: sections 301.010, 301.190 and 301.200, RSMo 2000.* *Original rule filed Dec. 2, 1986, effective March 12, 1987. Amended: Filed June 24, 2003, effective Dec. 30, 2003.*

**Original authority: 301.010, RSMo 1939, amended 1945, 1949, 1951, 1969, 1974, 1979, 1980, 1983, 1985, 1986, 1987, 1988, 1989, 1992, 1993, 1995, 1996, 1997, 1998, 2000; 301.190, RSMo 1939, amended 1947, 1965, 1981, 1983, 1984, 1985, 1986, 1987, 1988, 1989, 1990, 1992, 1993, 1999; and 301.200, RSMo 1939, amended 1947, 1984, 1986.*

12 CSR 10-23.375 Fire Department License Plates

(Rescinded March 30, 2005)

AUTHORITY: sections 301.144.2 and 301.444, RSMo 1986. *Original rule filed Jan. 5, 1987, effective April 11, 1987. Rescinded: Filed Sept. 16, 2004, effective March 30, 2005.*

12 CSR 10-23.380 Motor Vehicle Shows or Tent Sales

(Rescinded April 29, 1991)

AUTHORITY: section 301.254, RSMo 1986. *Original rule filed March 5, 1987, effective Aug. 27, 1987. Rescinded: Filed Nov. 15, 1990, effective April 29, 1991.*

12 CSR 10-23.385 Verification of the Vehicle Identification Number and Odometer Reading of Motor Vehicles Previously Titled in Another State

PURPOSE: This rule provides alternatives to the requirement for Missouri residents who are serving on active duty in the military and stationed outside Missouri; or residents who are located outside Missouri for an extended period of time; or residents who purchase nonoperable vehicles titled in another state to submit a Missouri motor vehicle inspection approval certificate with an application for Missouri title.

(1) A Missouri motor vehicle inspection approval certificate (see 11 CSR 50-2.120) from an official inspection station authorized by the Missouri State Highway Patrol which verifies the manufacturer's vehicle identification number and the vehicle's odometer reading shall accompany every application for a Missouri certificate of title to a motor vehicle which was previously titled in a state other than Missouri. The following alternatives to this requirement shall be available:

(A) A Missouri resident, on active duty in the military and stationed out-of-state, who purchases a vehicle previously titled in another state and is unable to transport it to Missouri for an inspection may submit a document signed by a commissioned officer of one of the United States Armed Forces verifying the manufacturer's identification number and odometer reading of the vehicle at the time application for title is made.

1. Example: John Doe (a Missouri resident who is a sergeant in the Army) purchases a motor vehicle in South Carolina. The South Carolina title is assigned to John Doe. Although Sgt. Doe will be stationed in South Carolina for two (2) years, he wants to title and register his motor vehicle in Missouri, his official domicile. Sgt. Doe cannot readily transport the vehicle to an official Missouri inspection station for an inspection because the vehicle is located outside Missouri; therefore, Sgt. Doe may submit a signed document in the form described in subsection (1)(A) of this rule with his application for title;

(B) A Missouri resident, located outside Missouri for an extended period of time due to employment, schooling, or others who purchases a vehicle previously titled in another state and is unable to transport it to Missouri for an inspection may present a notarized affidavit stating why the vehicle cannot be inspected in Missouri along with a notice of an inspection performed by an authorized inspection station or law enforcement officer in the state where the resident is located. The inspection shall verify the manufacturer's identification number and odometer reading of the vehicle.

1. Example: John Doe (a Missouri resident who is employed in Washington for two (2) years) purchases a motor vehicle in Washington. The Washington title is assigned to John Doe. Although Mr. Doe is employed in Washington for two (2) years, he wants to title and register his motor vehicle in Missouri, his official domicile. Mr. Doe cannot readily transport the vehicle to an official Missouri inspection station for an inspection because the vehicle is outside Missouri; therefore with his title application, Mr. Doe may submit a notarized affidavit stating why the vehicle cannot be inspected in Missouri and a notice of inspection which verifies the manufacturer's identification number of the vehicle and its odometer reading. The inspection shall be performed by either an authorized inspection station or law enforcement officer in Washington; or

(C) A Missouri resident purchases a vehicle previously titled in another state. The motor vehicle is not operational and is towed to the owner's legal address in Missouri. The

resident may submit a document signed by an authorized Missouri law enforcement officer who has verified the manufacturer's identification number and odometer reading of the vehicle.

1. Example: John Doe purchases a motor vehicle in Oklahoma. The Oklahoma title is assigned to John Doe. Since the motor vehicle is not operational, Mr. Doe has the vehicle towed to his legal address in Missouri. He wants to title his vehicle but cannot readily transport it to an official inspection station for an inspection. Mr. Doe may submit with his application for title a document signed by an authorized Missouri law enforcement officer who has verified the manufacturer's identification number and odometer reading of the nonoperable vehicle. The inspecting officer's report must clearly state that the vehicle is not operational.

AUTHORITY: section 301.190, RSMo 1986.* *Original rule filed May 11, 1987, effective Aug. 27, 1987.*

**Original authority: 301.190, RSMo 1939, amended 1947, 1965, 1981, 1983, 1984, 1985, 1986, 1986, 1987, 1988, 1989, 1990.*

12 CSR 10-23.390 License Plates for Disabled Veterans

(Rescinded May 30, 2006)

AUTHORITY: sections 301.071-301.075, RSMo 1986. *Original rule filed June 16, 1988, effective Nov. 24, 1988. Rescinded: Filed Nov. 8, 2005, effective May 30, 2006.*

12 CSR 10-23.395 Regulation of Boat Dealer's Certificate of Number and Plates

PURPOSE: The director of the Department of Revenue is charged with the responsibility of regulating the certificates of number issued to boat dealers and manufacturers. This rule establishes safeguards to prevent unauthorized use of certificates of number.

(1) Whenever a boat dealer or manufacturer is no longer entitled to registration under section 301.560, RSMo through voluntary cessation of business, abandonment of a bona fide established place of business, failure to make six (6) sales per year, suspension or revocation of its registration, sale of the business, declaration of bankruptcy or for any other reason, the certificates of number issued to that dealer shall be surrendered immediately to the director of revenue regardless of the unexpired time remaining in the registration period applicable to the certificates of number.



(2) Boat dealer certificates of number are issued primarily for the purpose of allowing a potential buyer to test drive a vessel or vessel trailer owned and held for resale by a dealer. A secondary purpose is to allow the transportation of vessels and vessel trailers owned by a boat dealer or manufacturer and held for the purpose of resale. Therefore, dealer certificates of number shall only be displayed on a vessel or vessel trailer that is—

(A) Owned by the boat manufacturer/dealer; and

(B) Held for resale.

(3) Vessels or vessel trailers on which the certificates of number are displayed may then be operated by—

(A) A customer who is test driving the unit; or

(B) An owner, officer or employee of the boat manufacturer/dealer.

(4) The certificates of number shall either be displayed on the outside of the vessel or be carried inside the vessel during any demonstration.

(5) In addition to obtaining a certificate of number, a boat dealer or manufacturer may obtain a metal boat dealer license plate solely for the purpose of demonstrating a vessel trailer that is owned by the dealer or manufacturer and held for resale. The boat dealer license plate may also be displayed on a vessel trailer which is transporting a vessel to an exhibit or show.

(A) The boat dealer license plate shall be twelve inches by six inches (12" × 6") in size and shall contain the boat dealer's registration number.

(B) A boat dealer license plate may be obtained upon payment of the same fees specified in section 301.560(6), RSMo and shall expire on December 31 of each year. These fees are prorated on a monthly basis.

1. Example: Upon the payment of the annual license fee set by law, a boat dealer shall be issued one (1) certificate of number for the purpose of test driving a vessel and one (1) boat dealer license plate for the purpose of demonstrating a vessel trailer.

(C) As many duplicate certificates of number or boat dealer license plates may be obtained as desired upon payment of the additional fee set by law for each additional certificate of number or boat dealer license plate requested. These fees are prorated on a monthly basis.

1. Example: Johnson Marina pays the annual fifty-dollar (\$50) registration fee to register as a Missouri boat dealer in January. It will be issued one (1) certificate of number

and one (1) boat dealer license plate upon payment of this fee. Johnson Marina requests three (3) additional certificates of number and two (2) additional boat dealer license plates at the time of registration. It will be charged an additional ten dollars and fifty cents (\$10.50) for each certificate of number and each boat dealer license plate requested (\$10.50 × 5 × \$2.50 × \$50.00 × \$102.50).

2. Example: Johnson Marina is a registered boat dealer and elects to obtain two (2) additional certificates of number and one (1) additional boat dealer license plate on April 5. Johnson Marina is required to pay the prorated fee of $\$7.88 \times 3 = \23.64 .

(6) Section 301.560, RSMo provides that certificates of number "may be displayed on any vessel or vessel trailer owned and held for resale by a boat dealer or manufacturer and used by a customer who is test driving the vessel or vessel trailer, or is used by an employee or officer, but shall not be displayed on any vessel or vessel trailer hired or loaned to others or upon any regularly used service vessel or vessel trailer." Therefore, dealer certificates of number shall be displayed on the following:

(A) Vessels or vessel trailers that are rented or leased;

(B) Vessels or vessel trailers that are loaned to someone other than an owner, officer or employee of the dealership (for example, a dealer may not loan a vessel displaying a certificate of number to the dealer's customer while the customer's vessel is being serviced or repaired);

(C) Vessels or vessel trailers that are used for hauling or towing;

(D) Vessels or vessel trailers used by anyone who is not an officer or employee of the manufacturer/dealer (vessel or vessel trailers shall not be used by relatives of employees and officers by virtue of that fact alone); or

(E) Vessels or vessel trailers that are not for resale.

AUTHORITY: section 301.560, RSMo Supp. 1990. Original rule filed July 17, 1989, effective Oct. 27, 1989.*

**Original authority: 301.560, RSMo 1988, amended 1989.*

12 CSR 10-23.400 Transfer of License Plates

PURPOSE: This rule clarifies when a motor vehicle or trailer owner may transfer license plates to a newly acquired motor vehicle or trailer and operate the vehicle for thirty days.

(1) Whenever a motor vehicle or trailer owner purchases a replacement motor vehicle or trailer from an individual or a dealership, the owner of a motor vehicle or trailer may operate the newly acquired motor vehicle or trailer with the transferred license plates for no more than thirty (30) days from the date of purchase, until making proper application for title and transfer of license plates with an office of the Department of Revenue.

(2) The license plates may only be transferred if the vehicle acquired is of the same vehicle category as the vehicle being replaced. Example: A passenger vehicle must be replaced by another passenger vehicle in order to attach passenger license plates. The vehicle owner may not use commercial vehicle (truck) license plates on a newly acquired passenger vehicle.

AUTHORITY: section 301.140, RSMo Supp. 1990. Original rule filed Feb. 2, 1990, effective May 11, 1990.*

**Original authority: 301.140, RSMo 1939, amended 1947, 1951, 1978, 1979, 1986, 1987.*

12 CSR 10-23.405 Emblem Use Authorization Statement and Format for Collegiate License Plates

PURPOSE: This rule clarifies the process to be used by colleges and universities in order to have personalized collegiate license plates available.

(1) Any community college or four (4)-year public or private institution of higher education located in Missouri authorizing the use of its official emblem to be affixed to a license plate annually must issue an emblem-use authorization statement. The statement must be on a form prescribed by the director of the Department of Revenue and must include the name of the community college or four (4)-year public or private institution, the applicant's name and address, the amount of fee paid and the date of payment.

(2) One (1) emblem-use authorization statement must be issued for each collegiate license plate application. A statement issued prior to July 1 of any calendar year shall be accepted for applications for collegiate license plates with an expiration month of the upcoming October, with the exception of collegiate license plates issued during the first year of issuance (1990). In this case, statements dated prior to July 1, 1991 will be accepted for applications for collegiate license plates with an expiration in October,



1991. Statements issued after the last day of June of any calendar year will be accepted for applications for collegiate license plates to be issued or renewed in the coming October with an expiration month of the next succeeding October.

(A) Example One: Emblem-use authorization statements dated before July 1, 1991 will result in issuance or renewal of collegiate license plates which expire in October 1991.

(B) Example Two: Emblem-use authorization statements dated after July 1, 1991 and before June 30, 1992 will result in issuance or renewal of collegiate license plates which expire in October 1992.

(3) Any community college or four (4)-year public or private institution of higher education which desires to have license plates issued which display its emblem, logo or seal must issue four hundred fifty (450) emblem-use authorization statements before the Department of Revenue will authorize the manufacture of license plates displaying its emblem, logo or seal.

(4) Should the community college or four (4)-year public or private institution of higher education be unable to issue four hundred fifty (450) emblem-use authorization statements, the institution must establish a mechanism for refunding the contributions to the applicant for these statements in the event refunds are requested by the applicant. Refunds shall only be made in the event the minimum number of emblem-use authorization statements are not issued.

(5) Any community college or four (4)-year public or private institution of higher education which desires to have collegiate license plates issued must submit a preliminary design of the emblem, logo or seal which it desires to be displayed upon the license plates as well as school colors that need to be included. This design must be formatted in accordance with the design of the plate as prescribed in section (6) of this rule. The department will submit the design to the vendor for the material to manufacture the plates. The vendor will prepare the finished artwork for the emblem, logo or seal and submit it to the Department of Revenue and the appropriate institution for approval. Upon approval, the department will authorize the manufacture of the plates, provided the community college or four (4)-year public or private institution of higher education has issued the required minimum number of emblem-use authorization statements and has notified the Department of Revenue in writing that the required minimum number of emblem-use

authorization statements have been issued to applicants.

(6) On the top of the collegiate license plate shall appear the words OCT and MO. The left-hand portion of the plate will bear a reproduction of the college emblem, seal or logo in an area not to exceed two and one-half inches by three inches (2 1/2" x 3"). Immediately to the right of the emblem, seal or logo, shall appear one to five (1-5) characters. The bottom of the license plate shall bear the name of the community college or public or private institution of higher education, in lieu of SHOW ME STATE, in an area not to exceed eleven inches by one inch (11" x 1").

AUTHORITY: section 301.449, RSMo Supp. 1990. Original rule filed Nov. 1, 1989, effective Feb. 25, 1990.*

**Original authority: 301.449, RSMo 1989.*

12 CSR 10-23.410 Certificate of Registration to Documented Vessels
(Rescinded February 25, 1996)

AUTHORITY: section 306.851, RSMo Supp. 1990. Emergency rule filed Nov. 2, 1990, effective Nov. 12, 1990, expired March 11, 1991. Original rule filed Nov. 2, 1990, effective March 14, 1996. Amended: Filed June 18, 1991, effective Oct. 31, 1996. Rescinded: Filed Sept. 1, 1995, effective Feb. 25, 1996.

12 CSR 10-23.415 Sample License Plates
(Rescinded November 30, 2007)

AUTHORITY: sections 301.130 and 301.449, RSMo Supp. 1990. Original rule filed Nov. 8, 1990, effective April 29, 1991. Rescinded: Filed May 23, 2007, effective Nov. 30, 2007.

12 CSR 10-23.420 Secure Power of Attorney Requirements

PURPOSE: This rule establishes the procedures for using a secure power of attorney in conjunction with a certificate of title as provided for in federal and state law.

PUBLISHER'S NOTE: The secretary of state has determined that the publication of the entire text of the material which is incorporated by reference as a portion of this rule would be unduly cumbersome or expensive. This material as incorporated by reference in this rule shall be maintained by the agency at its headquarters and shall be made available

to the public for inspection and copying at no more than the actual cost of reproduction. This note applies only to the reference material. The entire text of the rule is printed here.

(1) Section 407.536(8), RSMo and the Motor Vehicle Information and Cost Savings Act allow the transferor of a motor vehicle to execute a secure power of attorney (POA) when the certificate of ownership is held by a lienholder or for the purpose of assigning a duplicate title in order to comply with federal and state odometer disclosure requirements. The Secure Power of Attorney form, which has been incorporated by reference, published by the Missouri Department of Revenue, PO Box 100, Jefferson City, MO 65105-0100, contains a revision date of November 2005. The Secure Power of Attorney form does not include any amendments or additions to the November 2005 document.

(2) If the dealer sells the vehicle before the title is received as provided in section 301.894, RSMo, the dealer and purchaser may complete the secure POA to authorize the dealer to sign on behalf of the purchaser and make the odometer disclosure on the second title assignment so the purchaser is not required to return to the dealership once the title issues to acknowledge the disclosure. In this case, upon receipt of the title, the dealer must:

(A) Inspect the title to ensure the mileage on the title is consistent with what was recorded on the POA;

(B) Complete the first and second title assignments; and

(C) Complete the secure POA certifying that the mileage the dealer disclosed on the title document is consistent with the mileage provided to the dealer in the POA.

(3) The secure power of attorney form and corresponding certificate of ownership shall accompany the purchaser's application for title.

(4) Secure power of attorney forms and copies of corresponding titles received by a dealer in a particular month shall be submitted with the sales report completed for the month. If the dealer sales report is filed electronically, the POA forms and the title copies must be filed with the Department of Revenue by the fifteenth day of the month following the month in which the sale occurred. The dealer shall ensure that the original and all other copies of the secure power of attorney form and certificate of title are completed in full and are legible. The dealer shall



retain a photocopy of the secure power of attorney form and the front and back of the corresponding certificate of ownership as a part of the dealership's records for a period of five (5) years.

(5) A Missouri motor vehicle dealer may buy and sell a motor vehicle out-of-state when a secure power of attorney form accompanies the title. When an out-of-state secure power of attorney form is involved, the Missouri dealer shall obtain the appropriate copy of the secure power of attorney form and the certificate of title, but shall not be required to submit copies of those documents with the dealer's sales report.

(6) A motor vehicle dealer listed as the purchaser on the secure power of attorney form may elect to title the vehicle in the dealership's name by submitting the original secure power of attorney form and the original ownership document with the dealer's application for title.

AUTHORITY: sections 301.280, RSMo Supp. 2005 and 407.536.8, RSMo 2000. Emergency rule filed March 11, 1991, effective March 21, 1991, expired July 17, 1991. Emergency rule filed July 9, 1991, effective July 19, 1991, expired Nov. 15, 1991. Original rule filed March 11, 1991, effective Aug. 30, 1991. Amended: Filed July 2, 1992, effective Feb. 26, 1993. Amended: Filed June 24, 2003, effective Dec. 30, 2003. Amended: Filed Dec. 19, 2005, effective June 30, 2006.*

**Original authority: 301.280, RSMo 1939, amended 1974, 1983, 1984, 1986, 1988, 1990, 1993, 1997, 2004 and 407.536.8, RSMo 1977, amended 1983, 1988, 1989, 1990, 1992.*

12 CSR 10-23.422 Issuance of Purple Heart License Plates (Rescinded February 28, 2007)

AUTHORITY: sections 301.144, RSMo Supp. 1990 and 301.451, RSMo Supp. 1991. Emergency rule filed Sept. 16, 1991, effective Sept. 26, 1991, expired Jan. 23, 1992. Original rule filed Sept. 16, 1991, effective Jan. 13, 1992. Rescinded: Filed Aug. 23, 2006, effective Feb. 28, 2007.

12 CSR 10-23.424 Leasing Company Registration

PURPOSE: This rule sets forth the requirements for obtaining a permit to operate as a motor vehicle, trailer, boat or outboard motor leasing company.

(1) Any person, company or corporation engaged in the business of renting or leasing motor vehicles, trailers, boats or outboard motors either may elect to pay sales tax on the purchase price or elect to collect and remit sales tax on the gross receipts from the rental or lease of the motor vehicles, trailers, boats or outboard motors. Any person, company or corporation electing to collect and remit sales tax on the gross receipts from rental or lease shall apply to the director of revenue for a permit to operate as a leasing company.

(2) To apply for registration as a leasing company, the applicant shall submit a completed application on a biennial basis as prescribed by the director. A copy of the applicant's Missouri sales tax license shall accompany the initial application. The applicant also shall be properly registered with the Office of the Missouri Secretary of State and shall furnish proof of that registration upon request.

(3) Renewal applications for registration as a leasing company shall be filed with the director prior to December 1 of each registration period. Leasing company registrations shall expire on December 31 of each registration period. Leasing companies with expired registrations shall not be entitled to the sales tax option provided by section 144.070, RSMo, but shall pay all state and local sales tax on the purchase price of any units acquired while the registration is expired.

(4) Motor vehicles, trailers, boats and outboard motors purchased by a registered leasing company shall be titled in the name of the leasing company as registered with the director. The leasing company shall record its leasing permit number assigned by the director on all applications for title in order to be exempt from sales tax at the time of titling.

(5) Any transfer of a motor vehicle, trailer, boat or outboard motor to another division from one (1) division of a corporation which authorizes a division to register as a motor vehicle leasing company shall be a sale at retail as defined in section 144.010, RSMo.

(6) The director shall deny application for, or recall any permit to operate as a leasing company, if the applicant—

(A) Has fraudulently completed the application for registration;

(B) No longer holds a valid Missouri sales tax license; or

(C) Is no longer properly registered with the Office of the Missouri Secretary of State.

(7) A leasing company registered with the director pursuant to section 144.070, RSMo, which ceases to operate as a leasing company in accordance with the law, the rules established by the director, or both, shall notify the director accordingly and, within ten (10) days of cessation of operation, return the permit to operate as a leasing company to the director.

AUTHORITY: sections 144.010, RSMo Supp. 2003 and 144.070, RSMo 2000. Emergency rule filed Oct. 28, 1991, effective Nov. 7, 1991, expired March 6, 1992. Emergency rule filed Feb. 26, 1992, effective March 7, 1992, expired July 5, 1992. Original rule filed Oct. 28, 1991, effective May 14, 1992. Amended: Filed Oct. 10, 2003, effective April 30, 2004.*

**Original authority: 144.010, RSMo 1939, amended 1941, 1943, 1945, 1947, 1974, 1975, 1977, 1978, 1979, 1981, 1985, 1988, 1993, 1996, 1998, 1999, 2001 and 144.070, RSMo 1939, amended 1941, 1943, 1945, 1947, 1951, 1961, 1974, 1975, 1977, 1985, 1997.*

12 CSR 10-23.426 Special Identification Numbers

PURPOSE: This rule clarifies the issuance of special identification numbers to units seized by law enforcement because the identification number has been removed, covered, altered, destroyed or defaced and the procedures for obtaining these numbers.

(1) Section 301.390, RSMo provides that any motor vehicle, trailer, boat, outboard motor, vehicle part, motor vehicle tire, farm machinery, farm implement or construction equipment which has been seized by authorized law enforcement because the identification number has been removed, covered, altered, destroyed or defaced shall be placed in the custody of a court of competent jurisdiction. The court may not release that unit until a special identification number is issued by the Department of Revenue.

(2) In order to obtain a special identification number, the owner or purchaser of the unit shall submit—

(A) An Order for Special Identification Number executed by the circuit court that has custody of the unit. The attached sample order contains the format that should be used. The judge must sign and date the order;

(B) An Application for Replacement of Vehicle Identification Number Plate, DOR-923 (see 12 CSR 10-23.180), completed by the applicant and either the law enforcement



agency that seized the unit, an authorized member of the Missouri State Highway Patrol or other law enforcement agencies authorized by the director of revenue; and

(C) The appropriate fee for the special identification number.

(3) If the unit requiring a special identification number is a motor vehicle, trailer, boat or outboard motor, the owner or purchaser of the unit shall apply for a new certificate of title which shall reflect the new assigned identification number. To obtain a new certificate of title, the applicant shall submit the following in addition to the documents and fee outlined in section (2):

(A) An Application for Missouri Title and License, DOR-108 (see 12 CSR 10-23.265), completed and signed;

(B) The certificate of title if the unit is already titled in the applicant's name or a sheriff's bill of sale if ownership of the unit has been transferred by the court or a court order establishing ownership;

(C) The applicable title fee; and

(D) State and local taxes on the purchase price of the unit, if applicable.

(4) The Department of Revenue shall issue one (1) metal plate bearing the assigned identification number and a certificate of title reflecting this number on certain units as outlined in section (3). The metal plate shall be affixed to the unit and shall be the lawful number for the purpose of identification.

(5) The assigned special identification number shall consist of seventeen (17) characters. The special number shall begin with the two (2) letters as outlined in this rule, followed by thirteen (13) letters and numbers followed by MO.

(A) Motor vehicle or manufactured trailer—DR.

(B) Vehicle part or motor vehicle tire—VP.

(C) Farm machinery, farm implement or construction equipment—FC.

AUTHORITY: section 301.390, RSMo 1986.
Original rule filed April 23, 1992, effective Dec. 3, 1992.*

**Original authority: 301.390, RSMo 1939, amended 1953, 1982, 1986.*



IN THE CIRCUIT COURT OF _____ COUNTY, MISSOURI

_____)	
Plaintiff,)	
)	
vs.)	Case No. _____
)	
_____)	
Defendant.)	

ORDER FOR SPECIAL IDENTIFICATION NUMBER

NOW on this _____ day of _____, 19_____, after hearing the evidence and testimony presented, it is hereby found that:

1. (Complete description of motor vehicle trailer, boat, outboard motor, vehicle part, motor vehicle tire, farm machinery, farm implement or construction equipment seized including make, model, year, type of unit, etc.) was seized by (law enforcement agency) on _____, and was thereafter deposited into the custody of this court, in accordance with section 301.390, RSMo, because the identification number of the above-referenced unit(s) have been removed, covered, altered, destroyed or defaced.

2. _____ is the lawful owner of the above-described unit(s) and is entitled to possession thereof.

WHEREFORE, it is hereby ordered, adjudged and decreed that the Missouri Department of Revenue issue Special Identification Numbers for the above-described unit(s), upon proper application by the owner and payment of the appropriate fees. Upon proof of issuance of Special Identification Number(s) by the Department of Revenue, the above-referenced vehicle(s) shall be released to the owner(s) named herein.

_____	_____
Date	Judge



MISSOURI DEPARTMENT OF REVENUE
 MOTOR VEHICLE BUREAU
**APPLICATION FOR REPLACEMENT OF VEHICLE
 IDENTIFICATION NUMBER PLATE**

SEE INSTRUCTIONS ON REVERSE			
VALIDATION ONLY			
REGISTERED OWNER (LAST, FIRST, MIDDLE)			
STREET, R.R. OR P.O. BOX NUMBER			COUNTY
CITY, STATE, ZIP CODE			TELEPHONE NUMBER
YEAR	MAKE	BODY STYLE	VEHICLE IDENTIFICATION NUMBER
MISSOURI TITLE NUMBER	LICENSE NUMBER	LOSS OF VIN PLATE REPORT TO:	DATE
REASON REQUIRED			
<input type="checkbox"/> LOST <input type="checkbox"/> STOLEN <input type="checkbox"/> MUTILATED <input type="checkbox"/> DESTROYED			
I certify that the statements above are true and that I am the registered owner of the above described vehicle.			
NOTARY SEAL		APPLICANT'S SIGNATURE	
		SWORN TO AND DESCRIBED BEFORE ME THIS	
		DAY OF _____, 19____	
		NOTARY PUBLIC	COMMISSION EXPIRATION
I certify that on _____ I physically inspected the above described vehicle after the applicant provided satisfactory proof of ownership and found the vehicle identification number to be:			
LAW ENFORCEMENT AGENCY			FILE NUMBER
INSPECTING OFFICER			BADGE NUMBER
I certify that on _____ I did affix the replacement vehicle identification plate number _____ issued by the Department of Revenue to the above vehicle.			
LAW ENFORCEMENT AGENCY			
LAW ENFORCEMENT OFFICER			BADGE NUMBER

MO 860-0315 (9-86)

DISTRIBUTION: WHITE, YELLOW, PINK - DEPT. OF REVENUE
GOLDENROD - INSPECTING LAW ENFORCEMENT AGENCY

DOR-923 (9-86)



12 CSR 10-23.428 All-Terrain Vehicles Modified for Highway Use

(Rescinded December 30, 2005)

AUTHORITY: section 301.010, RSMo Supp. 1989, 301.190, RSMo Supp. 1990 and 301.700, Supp. 1988. Original rule filed April 23, 1992, effective Dec. 3, 1992. Emergency rescission filed June 9, 2005, effective June 19, 2005, expired Dec. 16, 2005. Rescinded: Filed June 9, 2005, effective Dec. 30, 2005.

12 CSR 10-23.430 Registration of a Motor Vehicle or Trailer When the Out-Of-State Lienholder Refuses to Release the Title

PURPOSE: This rule clarifies the requirements for and the issuance of registration by the Department of Revenue in certain situations for motor vehicles or trailers when an individual has established residency in Missouri and the out-of-state lienholder refuses to release the title.

(1) An individual establishing residency in Missouri is required to title and register all motor vehicles and trailers owned by him/her within thirty (30) days of establishing residency. On occasion, the lienholder named on the out-of-state title may refuse to release the title to either the owner or the Department of Revenue in order for the owner to title the vehicle in Missouri. Since the owner is obligated to obtain Missouri license plates for his/her vehicle, s/he shall apply for registration by submitting the following:

(A) APPLICATION FOR MISSOURI TITLE AND LICENSE, DOR-108 (see 12 CSR 10-23.265), completed and signed;

(B) A copy of the front and back of the out-of-state title issued in the owner's name;

(C) A written statement from the lienholder refusing to release the title;

(D) All documents and fees required to obtain Missouri license plates; and

(E) A fee equal to the title fee required pursuant to section 301.190, RSMo.

(2) The validated pink receipt from the application will serve as the applicant's registration certificate.

(3) No more than one (1) application for registration under this rule may be approved at any given time for a motor vehicle or trailer.

AUTHORITY: sections 301.010 and 301.190, RSMo Supp. 1992. Original rule filed April 16, 1993, effective Oct. 10, 1993.*

**Original authority: 301.010, RSMo 1939, amended 1945, 1949, 1951, 1969, 1974, 1979, 1980, 1983, 1985, 1986, 1987, 1988, 1989, 1992; 301.190, RSMo 1939, amended 1947, 1965, 1981, 1983, 1984, 1985, 1986, 1987, 1988, 1989, 1990, 1992.*

12 CSR 10-23.432 Registration of a Motor Vehicle or Trailer Subject to a Lease With a Right to Purchase Clause

PURPOSE: This rule clarifies the requirements for and the issuance of registration by the Department of Revenue in certain situations for motor vehicles or trailers which are the subjects of leases which contain a right to purchase clause.

(1) Under certain circumstances, the Department of Revenue will process an application for a Missouri registration which allows the applicant to obtain a Missouri certificate of registration and license plates for a motor vehicle or trailer when the applicant is not the title owner of the motor vehicle or trailer.

(2) Any person, firm, corporation or association which, as the result of entering into a lease agreement containing a right to purchase clause, is considered the owner of a motor vehicle or trailer, as that term is defined in section 301.010, RSMo, may make application for registration by submitting the following:

(A) APPLICATION FOR MISSOURI TITLE AND LICENSE, DOR-108 (see 12 CSR 10-23.265), completed and signed;

(B) A copy of the lease agreement containing a right to purchase clause that is signed by the lessor and the lessee;

(C) All documents and fees required to obtain Missouri license plates; and

(D) A fee equal to the title fee required pursuant to section 301.190, RSMo.

(3) The validated pink receipt from the application will serve as the applicant's registration certificate.

(4) No more than one (1) application for registration under this rule may be approved at any given time for a motor vehicle or trailer.

AUTHORITY: sections 301.010 and 301.190, RSMo Supp. 1992. Original rule filed April 16, 1993, effective Oct. 10, 1993.*

**Original authority: 301.010, RSMo 1939, amended 1945, 1949, 1951, 1969, 1974, 1979, 1980, 1983, 1985, 1986, 1987, 1988, 1989, 1992; 301.190, RSMo 1939, amended 1947, 1965, 1981, 1983, 1984, 1985, 1986, 1987, 1988, 1989, 1990, 1992.*

12 CSR 10-23.434 Use of a Reassignment of Ownership by Registered Dealer Form

PURPOSE: This rule clarifies who may use a Reassignment of Ownership by Registered Dealer (Rider) Form and when the form may be used.

(1) The Reassignment of Ownership by Registered Dealer (Rider) Form may be used by a registered Missouri motor vehicle dealer to make one (1) reassignment of ownership of a motor vehicle or trailer in addition to the reassignments contained on the back of a manufacturer's statement of origin or certificate of title when all existing reassignment spaces have been used.

(2) The Missouri rider form can only be—

(A) Used by a registered Missouri motor vehicle dealer; and

(B) Attached to a manufacturer's statement of origin, Missouri certificate of title or out-of-state certificate of title. The Missouri rider form cannot be used when ownership of the vehicle is transferred to the dealer on an out-of-state rider.

(3) Only one (1) Missouri rider may be attached to a manufacturer's statement of origin, Missouri certificate of title or out-of-state certificate of title.

(4) The Reassignment of Ownership by Registered Dealer (Rider) Form must be on a secure form approved by the director of revenue. Forms 2447 and M2447 follow this rule.

AUTHORITY: section 301.200, RSMo 1986. Emergency rule filed July 30, 1993, effective Aug. 9, 1993, expired Dec. 6, 1993. Original rule filed July 30, 1993, effective Jan. 31, 1994.*

**Original authority: 301.200, RSMo 1939, amended 1947, 1984, 1986.*



MISSOURI DEPARTMENT OF REVENUE MOTOR VEHICLE BUREAU REASSIGNMENT OF OWNERSHIP BY REGISTERED DEALER		FORM 2447 (REV. 4-92)	MUST BE PRINTED LEGIBLY
<p>THIS REASSIGNMENT BY A REGISTERED DEALER FORM (DOR-2447) MAY BE USED ONLY BY A REGISTERED MISSOURI DEALER WHEN MAKING AN ASSIGNMENT OF OWNERSHIP ON MANUFACTURER'S STATEMENT OF ORIGIN OR CERTIFICATE OF TITLE CONTAINING LESS THAN FOUR ASSIGNMENT SPACES. Only one of these forms may be used and must be securely attached to the accompanying Manufacturer's Statement of Origin or Certificate of Title.</p> <p>WARNING: ALTERATIONS OR ERASURES WILL VOID THIS REASSIGNMENT OF OWNERSHIP BY A REGISTERED DEALER FORM.</p> <p>INSTRUCTIONS TO SELLER: Complete ALL spaces below except the blocks for the signature and printed names of the purchaser. Complete the mileage block as of the date of sale or transfer. Sign and hand print your name as seller only after the purchaser has signed and hand printed their name. Also record your position with the dealership. You state under penalty of perjury that the total purchase price represents the total amount collected for the sale of this vehicle.</p> <p>INSTRUCTIONS TO PURCHASER: You must sign and hand print your name in the area provided.</p>			
VEHICLE IDENTIFICATION NUMBER	YEAR	MAKE	
TITLE NUMBER	MODEL	BODY STYLE	
I/We hereby assign and warrant the Manufacturer's Statement of Origin or Certificate of Title of the vehicle described on the face of the Manufacturer's Statement of Origin or Certificate of Title to which this form is attached and I/we certify the accuracy of the sale price and mileage as specified below subject to the following lien or encumbrance, if any.			
PURCHASER(S) NAME (PRINTED OR TYPED)		SALE PRICE BY SELLER	
ADDRESS		\$	
LIENHOLDER(S) NAME (PRINTED OR TYPED)		DATE OF SALE	
ADDRESS		DATE OF LIEN	
ODOMETER READING (NO TENTHS)	I state that the odometer now reads the aforementioned miles and to the best of my knowledge that it reflects the actual mileage of the vehicle described herein, unless one of the following statements is checked.		
	<input type="checkbox"/> MILEAGE IN EXCESS OF ITS MECHANICAL LIMITS <input type="checkbox"/> MILEAGE READING NOT ACTUAL (WARNING: ODOMETER DISCREPANCY)		
SIGNATURE OF PURCHASER(S)		SIGNATURE OF SELLER(S)	
HAND PRINTED NAME(S) BY PURCHASER (AGENT/POSITION)		HAND PRINTED NAME(S) BY SELLER(S) (AGENT/POSITION)	
DEALER NUMBER, IF APPLICABLE		DEALER NUMBER	
DISTRIBUTION: WHITE ORIGINAL-attach to Manufacturer's Statement of Origin or Certificate of Title; PINK-retain for dealer's records.		NO. 1054809	

MO 860-0387 (4-92)



REASSIGNMENT OF OWNERSHIP BY REGISTERED DEALER		FORM M2447 (REV. 4-93)	MUST BE PRINTED LEGIBLY
<p>THIS REASSIGNMENT BY A REGISTERED DEALER (RIDER) MAY BE USED ONLY BY A REGISTERED MISSOURI DEALER WHEN MAKING AN ASSIGNMENT OF OWNERSHIP ON A MANUFACTURER'S STATEMENT OF ORIGIN OR CERTIFICATE OF TITLE. ONLY ONE OF THESE FORMS MAY BE USED AND MUST BE SECURELY ATTACHED TO THE ACCOMPANYING MANUFACTURER'S STATEMENT OF ORIGIN OR CERTIFICATE OF TITLE.</p> <p>WARNING: ALTERATIONS OR ERASURES WILL VOID THIS REASSIGNMENT OF OWNERSHIP BY A REGISTERED DEALER.</p> <p>INSTRUCTIONS TO SELLER: Complete ALL spaces below except the blocks for the signature and printed names of the purchaser. Complete the mileage block as of the date of sale or transfer. Sign and hand print your name as seller, only after the purchaser has signed and hand printed their name. Also record your position with the dealership. You state under penalty of perjury that the total purchase price represents the true amount collected for the sale of this vehicle.</p> <p>INSTRUCTIONS TO PURCHASER: You must sign and hand print your name in the area provided.</p>			
VEHICLE IDENTIFICATION NUMBER		YEAR	MAKE
TITLE NUMBER		MODEL	BODY STYLE
<p>I/We hereby assign and warrant the Manufacturer's Statement of Origin or Certificate of Title for the vehicle described on the face of the Manufacturer's Statement of Origin or Certificate of Title to which this form is attached and I/we certify the accuracy of the sale price and mileage as specified below subject to the following lien or encumbrance if any.</p>			
PURCHASER(S) NAME (PRINTED OR TYPED)		SALE PRICE BY SELLER	
ADDRESS		DATE OF SALE	
LIENHOLDER(S) NAME (PRINTED OR TYPED)		DATE OF LIEN	
ADDRESS			
ODOMETER READING (NO TENTHS)	<p>I state that the the odometer now reads the aforementioned miles and to the best of my knowledge that it reflects the actual mileage of the vehicle described herein, unless one of the following statements is checked.</p> <p><input type="checkbox"/> MILEAGE IN EXCESS OF ITS MECHANICAL LIMITS</p> <p><input type="checkbox"/> MILEAGE READING NOT ACTUAL (WARNING: ODOMETER DISCREPANCY)</p>		
SIGNATURE OF PURCHASER(S)		SIGNATURE OF SELLER(S)	
HAND PRINTED NAME(S) BY PURCHASER (AGENT/POSITION)		HAND PRINTED NAME(S) BY SELLER(S) (AGENT/POSITION)	
DEALER NUMBER, IF APPLICABLE		DEALER NUMBER	
<p>DISTRIBUTION: WHITE ORIGINAL-attach to Manufacturer's Statement of Origin or Certificate of Title; PINK-retain for dealer's records.</p>			

REORDER FORM #M2447 (4/93) MADA P.O. BOX 1158, JEFFERSON CITY, MO. 65102



12 CSR 10-23.436 Application For Title
(Rescinded December 30, 2003)

AUTHORITY: sections 301.190, 301.700 and 700.320, RSMo 1994. Original rule filed Nov. 28, 1994, effective May 28, 1995. Rescinded: Filed June 24, 2003, effective Dec. 30, 2003.

12 CSR 10-23.440 Replacement License Tabs
(Rescinded May 30, 2006)

AUTHORITY: section 301.301, RSMo Supp. 1995. Original rule filed Sept. 1, 1995, effective Feb. 25, 1996. Rescinded: Filed Nov. 1, 2005, effective May 30, 2006.

12 CSR 10-23.442 Outboard Motor

PURPOSE: This rule defines the type of outboard motor required to be titled and registered.

(1) An outboard motor is defined as an internal combustion engine with an integrally attached propeller or waterjet propulsion unit that is designed to be temporarily secured to the stern of a boat.

(2) Only outboard motors, as defined above, are subject to the titling and registration requirements of Chapter 306, RSMo.

AUTHORITY: section 306.530, RSMo 1994.* Emergency rule filed March 12, 1999, effective March 22, 1999, expired Sept. 17, 1999. Original rule filed March 12, 1999, effective Aug. 30, 1999.

*Original authority: 306.530, RSMo 1945, amended 1949, 1985.

12 CSR 10-23.444 Historic Vehicle License
(Rescinded December 30, 2003)

AUTHORITY: section 301.131, RSMo Supp. 1998. Original rule filed March 12, 1999, effective Sept. 30, 1999. Rescinded: Filed June 24, 2003, effective Dec. 30, 2003.

12 CSR 10-23.446 Notice of Lien

PURPOSE: This rule outlines the requirements for the perfection of a lien on a motor vehicle, trailer, manufactured home, all terrain vehicle, boat or outboard motor by physical delivery or electronic filing of the notice of lien.

PUBLISHER'S NOTE: The secretary of state has determined that the publication of the entire text of the material which is incorporated by reference as a portion of this rule would be unduly cumbersome or expensive. This material as incorporated by reference in this rule shall be maintained by the agency at its headquarters and shall be made available to the public for inspection and copying at no more than the actual cost of reproduction. This note applies only to the reference material. The entire text of the rule is printed here.

(1) A lien on a motor vehicle, trailer, manufactured home, all terrain vehicle, boat or outboard motor is perfected when a notice of lien meeting the requirements in section (2) is delivered to the director of revenue, whether or not the ownership thereof is being transferred. A processing fee is collected when the notice of lien is delivered to the director. Delivery to the director of revenue may be physical delivery of the notice of lien to the director by mail, or to the director or agent of the director in a Department of Revenue office, or by electronic filing of the notice of lien. A received date stamp placed on the notice of lien application receipt or an electronic confirmation receipt issued by the director or his/her agent will be prima facie proof of the date of delivery. If ownership is not being transferred the lien may not be filed electronically because, the lienholder must also submit the application for title, the ownership document, title fee and processing fees with the notice of lien or with the Notice of Lien box marked on the title application on behalf of the owner to have a new title produced reflecting the lien.

(2) A notice of lien for a motor vehicle, trailer, manufactured home, all terrain vehicle, boat or outboard motor shall be in a form or electronic format provided or approved by the director of revenue entitled "Notice of Lien" or on the title application of ownership is not transferred by marking the Notice of Lien box. The Notice of Lien shall contain, but not be limited to, the following information:

- (A) Name and address of owner(s);
- (B) Unit description, by make, and identification number;
- (C) Purchase date;
- (D) Name and address of first and second lienholder(s), if applicable; and
- (E) Subject to future advances if applicable.

(3) The Notice of Lien or Lien Release (revised 11-03), which has been incorporated by reference, is published by the Missouri Department of Revenue, PO Box 100, Jeffer-

son City, MO 65105-0100. The form does not include any amendments or additions to the revision/publication date shown. It is available at all contract offices and the department's central office, or may be ordered at <http://www.dort.mo.gov/mvdl/formorder/> or by mailing a written request to the Missouri Department of Revenue, PO Box 100, Jefferson City, MO 65105-0100.

(4) As used in this rule, the term "boat" includes all motorboats, vessels or watercraft as the terms are defined in section 306.010, RSMo.

(5) Any lienholder who elects to file a lien electronically must apply to use this option and be approved by the director.

AUTHORITY: sections 301.600, 301.610, 301.620, 301.660, 306.400, 306.405, 306.410, 306.430, 700.350, 700.355, 700.360 and 700.380, RSMo Supp. 2006.* Emergency rule filed Aug. 18, 1999, effective Aug. 28, 1999, expired Feb. 23, 2000. Original rule filed Aug. 18, 1999, effective Feb. 29, 2000. Amended: Filed June 13, 2000, effective Dec. 30, 2000. Amended: Filed April 9, 2003, effective Oct. 30, 2003. Amended: Filed Oct. 6, 2006, effective April 30, 2007.

*Original authority: 301.600, RSMo 1965, amended 1989, 1999, 2000, 2001, 2002; 301.610, RSMo 1965, amended 1990, 1992, 1999, 2002; 301.620, RSMo 1965, amended 1990, 1992, 1999, 2002; 301.660, RSMo 1965, amended 1990, 2002; 306.400, RSMo 1985, amended 1999, 2000, 2002; 306.405, RSMo 1985, amended 1999, 2002; 306.410, RSMo 1985, amended 1999, 2000, 2002; 2003; 306.430, RSMo 1985, amended 2002; 700.350, RSMo 1985, amended 1989, 2002; 700.355, RSMo 1985, amended 2002; 700.360, RSMo 1985, amended 2002; and 700.380, RSMo 1985, amended 2002.

12 CSR 10-23.450 Guidelines for Use of Handicapped Parking Cones

PURPOSE: This rule establishes guidelines for the use of handicapped parking cones.

(1) Any person who is issued disabled person license plates or a removable windshield placard and who uses a wheelchair or transports a person who uses a wheelchair, may utilize a parking cone bearing the international symbol of accessibility and the words "wheelchair parking space."

(2) Parking cones shall be predominantly orange, fluorescent red-orange or fluorescent yellow-orange, not less than eighteen inches (18") in height and shall be made of a material that can be struck without damaging vehicles on impact.



(3) Any cone that conforms to the requirements of this provision will be sufficient for use by such person without further authorization from the director.

AUTHORITY: section 301.139, RSMo Supp. 1999. Original rule filed Oct. 27, 1999, effective May 30, 2000.*

**Original authority: 301.139, RSMo 1999.*

12 CSR 10-23.452 Internet Renewal of License Plates

PURPOSE: This rule will allow Missouri citizens to renew their Missouri license plates via the Missouri On-Line Registration Exchange, Missouri Internet Vehicle Registration Renewal System, by using a Personal Identification Number.

(1) Any person desiring to renew their Missouri license plates via the Missouri On-Line Registration Exchange (MORE), Missouri Internet Vehicle Registration Renewal System, must use the eight (8) digit Personal Identification Number (PIN) recorded on their renewal notice. Entering the PIN into the Missouri Internet Vehicle Registration Renewal System shall be deemed the signature of the owner where a signature is required. This includes certification by the vehicle owner that he/she has and will maintain, during the period of registration, financial responsibility with respect to each motor vehicle that is owned, licensed or operated on the streets or highways.

(2) Only vehicle owners whose county (including the City of St. Louis) has provided the owner's personal property tax records to the Department of Revenue's Personal Property Tax Record System may have the option of renewing the license plates via the Missouri Internet Vehicle Registration Renewal System.

(3) Only vehicle owners displaying regular or personalized license plates in one of the following categories may use the Missouri Internet Vehicle Registration Renewal System for vehicle renewal purposes:

(A) Motor vehicles subject to the registration fees according to horsepower, as provided in section 301.055, RSMo;

(B) Local and beyond local property-carrying commercial motor vehicles licensed for a gross weight not to exceed fifty-four thousand (54,000) pounds;

(C) Trailers, excluding trailers displaying a three (3)-year trailer plate;

(D) Recreational vehicles;

(E) Motorcycles and motortricycles;

(F) Shuttle buses;

(G) Van pool; and

(H) Private school buses.

(4) Vehicles owners who must annually present an Emblem Use Authorization Statement issued by the organization cannot renew their registration through the Missouri Internet Vehicle Registration Renewal System.

(5) If a vehicle owner enters information into the Missouri Internet Vehicle Registration Renewal System indicating that his/her vehicle has been out-of-state for the past sixty (60) days and he/she is unable to enter a vehicle safety or emissions inspection number, if applicable, the owner must enter the out-of-state address. The Missouri Department of Revenue will mail the validation tabs to the out-of-state address entered by the applicant.

AUTHORITY: section 32.300, RSMo 2000. Original rule filed June 7, 2001, effective Dec. 30, 2001.*

**Original authority: 32.300, RSMo 2000.*

12 CSR 10-23.454 Electric Personal Assistive Mobility Device (EPAMD)

PURPOSE: This rule gives the definition, titling and registration requirements of an Electric Personal Assistive Mobility Device (EPAMD) pursuant to section 307.205.1, RSMo.

(1) An Electric Personal Assistive Mobility Device (EPAMD) is a nontandem two-wheeled device with an electric propulsion system of one (1) horsepower with maximum speed of less than twenty (20) miles per hour. The device meets the definition of a motorized bicycle as defined in section 301.010(36), RSMo and is therefore exempt from titling and registration pursuant to Chapter 301, RSMo.

AUTHORITY: sections 301.010 and 301.190, RSMo 2000 and 307.205, RSMo Supp. 2002. Original rule filed Aug. 23, 2002, effective Feb. 28, 2003.*

**Original authority: 301.010, RSMo 1939, amended 1945, 1949, 1951, 1969, 1974, 1979, 1980, 1983, 1983, 1985, 1986, 1986, 1987, 1988, 1989, 1992, 1993, 1995, 1996, 1997, 1998, 2000; 301.190, RSMo 1939, amended 1947, 1965, 1981, 1983, 1984, 1985, 1986, 1986, 1987, 1988, 1989, 1990, 1992, 1997, 1999; and 307.205, RSMo 2002.*

12 CSR 10-23.456 Marine Application for Title

PURPOSE: This rule clarifies when the Application for Missouri watercraft or Outboard Motor Title and Registration (DOR-93 revision date of March 2003) must be used.

(1) Effective July 1, 2003, the department will begin issuing the revised Application for Missouri Watercraft or Outboard Motor Title and Registration form (DO-93 revision date of March 2003). This form can be requested from the department of revenue's website at <http://www.dort.state.mo.us/mvd1/formorder>.

(2) All Missouri dealers, lienholders, and applications must submit this form when applying for title and registration on an outboard motor or vessel.

(3) Previous versions of the application form (DOR-93) may no longer be accepted on or after December 31, 2003.

AUTHORITY: sections 306.400 and 306.410, RSMo Supp. 2003. Original rule filed May 22, 2003, effective Dec. 30, 2003.*

**Original authority: 306.400, RSMo 1985, amended 1999, 2000, 2002; 306.410, RSMo 1985, amended 1999, 2000, 2002.*

12 CSR 10-23.458 Documents Accepted as a Release of Lien

PURPOSE: This rule clarifies what documents are acceptable to the Department of Revenue to release a lien on a motor vehicle, trailer, all-terrain vehicle, outboard motor, vessel, or manufactured home.

(1) Every release of lien for a motor vehicle, trailer, all-terrain vehicle, outboard motor, vessel, or manufactured home issued on or after July 1, 2003, must be notarized.

(2) The following notarized documents will be accepted as a lien release for liens released on or after July 1, 2003.

(A) Notice of Lien Release (DOR-4809), which can be requested from the Department of Revenue's website at <http://www.dort.state.mo.us/mvd1/formorder>; or

(B) Lien release issued on the lienholder's business letterhead. The release shall contain the owner's name, year, make, vehicle identification number, lien release date, and lienholder name and signature.



AUTHORITY: sections 301.640, 306.410, 306.420 and 700.370, RSMo Supp. 2003. Original rule filed June 24, 2003, effective Dec. 30, 2003.*

**Original authority: 301.640, RSMo 1965, amended 1990, 1992, 1998, 1999, 2002; 306.410, RSMo 1985, amended 1999, 2000, 2002; 306.420, RSMo 1985, amended 1999, 2000, 2002; 700.370, RSMo 1985, amended 2002.*

12 CSR 10-23.460 Issuance of Biennial Disabled Person Placard

(Rescinded November 30, 2007)

AUTHORITY: sections 301.003, RSMo 2000 and 301.142, RSMo Supp. 2004. Original rule filed Nov. 13, 2003, effective May 30, 2004. Amended: Filed Dec. 14, 2004, effective July 30, 2005. Rescinded: Filed May 23, 2007, effective Nov. 30, 2007.

12 CSR 10-23.465 Issuance of Biennial Salvage Business Licenses

PURPOSE: This rule provides for issuing biennial salvage business licenses on a staggered basis to equalize the Department of Revenue's workload and for the corresponding fees that are required.

(1) Salvage business licenses expire June 30 of the designated expiration year. The renewal period begins April 1 in the year of their expiration.

(A) New applicants for salvage business licensure processed on or after August 28, 2004, will be issued a two (2)-year license expiring June 30 of the appropriate year. The cost for licensure shall be one hundred thirty dollars (\$130) for each type of business activity indicated on the application, except that only one (1) one hundred thirty dollar (\$130) fee shall be collected if the applicant applies for licensure as a used parts dealer and a salvage dealer or dismantler. If the licensure period is for less than a two (2)-year period, the licensure fee shall be prorated for each type of business activity on a quarterly basis based on application receipt date as follows:

1. July 1 to September 30—one hundred thirty dollars (\$130)
2. October 1 to December 31—one hundred thirteen dollars and seventy-five cents (\$113.75)
3. January 1 to March 31—ninety-seven dollars and fifty cents (\$97.50)
4. April 1 to June 30—eighty-one dollars and twenty-five cents (\$81.25)

(B) Late renewal applicants who submitted their application for a salvage business license before August 28, 2004, but who are

not approved until on or after August 28, 2004, will receive a one (1)-year license expiring June 30, 2005, at a cost of sixty-five dollars (\$65) for each type of business activity conducted.

(C) Late renewal applicants who submit their application for a salvage business license on or after August 28, 2004, have the option of receiving a one (1)-year or two (2)-year license. These applicants must obtain a certification from authorized law enforcement as required by section 301.219, RSMo.

(D) Renewal applicants for salvage business licensure who renew during the renewal cycle beginning April 1, 2005, and who have an even-numbered license number, will be issued a one (1)-year license expiring June 30, 2006, at a cost of sixty-five dollars (\$65) for each business activity conducted. During the renewal cycle beginning April 1, 2006, these renewal applicants will be issued a two (2)-year license expiring June 30, 2008.

(E) Renewal applicants for salvage business licensure who renew during the renewal cycle beginning April 1, 2005, and who have an odd-numbered license number, will be issued a two (2)-year license expiring June 30, 2007, at a cost of one hundred thirty dollars (\$130) for each business activity conducted.

(2) Each application for a salvage business license must be accompanied by a five-dollar (\$5) fee for a criminal record check for each owner, partner, or corporate officer listed on the application. The deposited fees are forwarded to the Missouri State Highway Patrol. The patrol shall provide the director with the results of the applicant's criminal record check to assist the director in determining the applicant's qualifications as provided in section 301.221, RSMo.

(3) In the event that owners, partners, or principal officers (if a corporation) are residents of a state other than Missouri or another country, they must obtain a current criminal record check from their state highway patrol or corresponding law enforcement agency and submit that record check with new and renewal applications. The five-dollar (\$5) fee referenced in section (2) of this rule is inapplicable to this circumstance.

AUTHORITY: sections 301.219 and 301.221, RSMo Supp. 2004 and 301.229, RSMo 2000. Original rule filed Sept. 16, 2004, effective March 30, 2005.*

**Original authority: 301.219, RSMo 1979, amended 1986, 2004; 301.221, RSMo 1979, amended 1986, 2004; and 301.229, RSMo 1979, amended 1988.*

12 CSR 10-23.470 Notice of Sale

PURPOSE: Section 301.196, RSMo, requires the seller of a motor vehicle, trailer, or all-terrain vehicle to report the sale to the Department of Revenue. Section 301.280, RSMo, requires dealers who do not file their monthly sales reports electronically to submit a notice of sale as required by section 301.196, RSMo, with their monthly sales report. This rule establishes the forms for reporting the sale to the department.

PUBLISHER'S NOTE: The secretary of state has determined that the publication of the entire text of the material which is incorporated by reference as a portion of this rule would be unduly cumbersome or expensive. This material as incorporated by reference in this rule shall be maintained by the agency at its headquarters and shall be made available to the public for inspection and copying at no more than the actual cost of reproduction. This note applies only to the reference material. The entire text of the rule is printed here.

(1) When selling a motor vehicle, trailer, or all-terrain vehicle to a Missouri resident, the seller must report the sale to the Department of Revenue.

(A) Sellers, other than Missouri licensed dealers, must complete one (1) of the following forms and submit it to the Department of Revenue within thirty (30) days of the sale.

1. Notice of Sale, (Form DOR 5049), required when title does not include the perforated notice of sale;

2. The Notice of Sale (Form DOR 5049A) portion of the Missouri Certificate of Title; or

3. Bill of Sale (Form DOR 1957), used when applying for a tax credit under section 144.025, RSMo. Notice of Sale, (Form DOR 5049), revised October 2005, Notice of Sale (Form DOR 5049A) portion of the Missouri Certificate of Title, revised July 2005, and the Bill of Sale (Form DOR 1957), revised August 2005, are incorporated by reference, are published by and can be obtained from the Missouri Department of Revenue, PO Box 100, Jefferson City, MO 65105-0100. These forms do not include any amendments or additions since the revision dates noted.

(B) Missouri licensed dealers who do not file their sales reports electronically must complete a Notice of Sale using Form DOR 5049 and DOR 5049A for each retail sale made to a Missouri resident and submit the forms with the corresponding dealer's monthly sales reports.



AUTHORITY: sections 301.196, 301.197, 301.198 and 301.280, RSMo Supp. 2005.
Original rule filed Dec. 19, 2005, effective June 30, 2006.*

**Original authority: 301.196, RSMo 2004; 301.197, RSMo 2004; 301.198, RSMo 2004; and 301.280, RSMo 1939, amended 1974, 1983, 1984, 1986, 1988, 1990, 1993, 1997, 2004.*